

Installation instructions for devices in the series PSC1-C-10

- PSC1-C-10
- PSC1-C-10-MC⁽¹⁾
- PSC1-C-10-FBx⁽²⁾
- PSC1-C-10-SDM1
- PSC1-C-10-SDM1-MC⁽¹⁾
- PSC1-C-10-SDM1-FBx⁽²⁾
- PSC1-C-10-SDM2
- PSC1-C-10-SDM2-MC⁽¹⁾
- PSC1-C-10-SDM2-FBx⁽²⁾

and their expansion modules

- PSC1-E-31-12DI-10DIO
- PSC1-E-33-12DI-6DIO-4RO
- PSC1-E-37-14DI-4DO-2RO-RIO⁽³⁾

Options:

- (1) Memory Card to store the configuration, the program and the data; see under:
- (2) For version see: "Optional universal communication interface"
- (3) in preparation

Note:

The German version is the original version of the installation instructions

As of: 05/2017

Valid from firmware release 5.0.0.1

Subject to technical change without notice.

The content of this documentation has been prepared with the greatest possible care and corresponds to the latest information available to us.

Nevertheless, we draw your attention to that fact that this document cannot always be updated simultaneously

with the technical further development of our products.

Information and specifications may be changed at any time. Please obtain information on the latest version at: www.schmersal.net.

K. A. Schmersal GmbH & Co. KG
Möddinghofe 30
42279 Wuppertal

Revision history

Version-No.	Date	Comment
V 1.0	Feb 2 nd , 2017	Release
- V 2.0	May 2 nd , 2018	Editorial changes
V 2.1	Oct 31 th , 2018	Terminal designation CPU-ENC/ENC adapted, DC value specified for 2x Proxy 2, X22 without function with PSC1-E-(1)33-..., CANopen added, Reference to protective circuit for contactors, etc., Additional reference to derating in Chap. 4.3.4, Note on the use of the read-back contacts on the PSC1-E-(1)33-... module,

Contents

1	IMPORTANT NOTES	8
2	DEFINITIONS	8
2.1	Reference documents.....	9
2.2	Abbreviations used.....	10
3	SAFETY INSTRUCTIONS	11
3.1	Intended use.....	11
3.2	Usage in regions with UL/CSA requirement	12
3.3	General safety instructions	13
3.4	Operating and service.....	14
3.5	Transport/storage	15
3.6	Module overview.....	16
3.7	Device characteristic data.....	17
3.7.1	Basic modules	17
3.7.1.1	PSC1-C-10 (-FBx ⁽¹⁾)/-MC).....	17
3.7.1.2	Tech. characteristic data PSC1-C-10 (-FBx ⁽¹⁾ /MC)	19
3.7.1.3	PSC1-C-10-SDM1 (-FBx ⁽¹⁾ /MC).....	21
3.7.1.4	Tech. characteristic data PSC1-C-10-SDM1 (-FBx ⁽¹⁾ /MC)	23
3.7.1.5	PSC1-C-10-SDM2 (-FBx ⁽¹⁾ /MC).....	25
3.7.1.6	Tech. characteristic data PSC1-C-10-SDM2 (-FBx ⁽¹⁾).....	27
3.7.2	Central expansion modules	29
3.7.2.1	PSC1-E-31 and PSC1-E-33	29
3.7.2.2	Tech. characteristic data: PSC1-E-31 and PSC1-E-33.....	31
3.7.3	Decentralised expansion modules (in preparation)	33
3.7.3.1	PSC1-E-37.....	33
3.7.3.2	Tech. characteristic data: PSC1-E-37	34
3.7.4	Optional universal communication interface.....	36
3.7.4.1	Tech. characteristic data: Optional universal communication interface	37
3.7.4.2	Possible combinations	38
3.7.4.3	Using the memory card	38
3.7.5	Encoder specifications.....	39
3.8	Derating outputs	39
3.9	Marking.....	40
3.9.1	Type plate	40
3.9.2	Items supplied.....	41
4	SAFETY-RELATED FEATURES	42
4.1	General layout, safety-related architecture and characteristic data	42
4.2	Safety-related characteristic data and circuitry for sensors connected	44
4.2.1	Digital sensors:	44
4.2.1.1	Characteristics of the sensors / input elements.....	44
4.2.1.2	DC digital sensors/inputs	45
4.2.1.3	Classification of the safe digital inputs.....	49
4.2.1.4	Connection examples, digital sensors/safety switch	51
4.2.1.5	Overview of achievable PL for digital safety inputs	56
4.2.2	Sensors for speed and/or position acquisition.....	58
4.2.2.1	General safety-related layout of sensor interface for position and/or speed	58
4.2.2.2	General diagnostic measures for encoder interface.....	59
4.2.2.3	Encoder types and their combinations, diagnostic characteristic data.....	60
4.2.2.4	Specific diagnostic measures in relation to the encoder type used	66
4.2.2.5	Safety-related shutdown thresholds, encoder systems for position and speed acquisition	67
4.2.2.6	Safety-related assessment of the encoder types and their combination.....	71

4.3	Safety-related characteristic data and circuitry for the outputs	73
4.3.1	Characteristics of the output elements	73
4.3.2	Diagnostics in the shutdown circuit	75
4.3.2.1	Diagnostic functions	75
4.3.2.2	Overview of DC in relation to selected diagnostic functions	76
4.3.3	Permissible capacitive and inductive load on safe outputs	77
4.3.4	Digital outputs	78
4.3.4.1	Example circuits, basic outputs	80
4.3.5	Digital outputs I/O (IQQx)	87
4.3.5.1	Classification of the I/O (IQQx) on usage as an output	87
4.3.5.2	Example circuits for safe digital outputs I/O (IQQx)	88
4.3.5.3	Overview of achievable PL for digital safety outputs	94
5	CONNECTION AND INSTALLATION	96
5.1	General installation instructions	96
5.2	Installation and mounting PSC1 module	97
5.3	Mounting backplane bus	97
5.3.1	Arrangement examples	98
5.3.1.1	PSC1-C-10-SDM1 + PSC1-E-31-... + PSC1-E-33-...	98
5.3.1.2	PSC1-C-10-SDM2 + PSC1-E-33-...	98
5.4	Mounting the modules	99
5.4.1	Mounting on C rail	99
5.4.2	Mounting on backplane bus	100
5.5	Installation and configuration of master ↔ master (SMMC) and master ↔ slave (SDDC)	101
5.5.1	Schematic diagram of the network topology	102
5.6	Installation of I/O expansion	103
5.6.1.1	Physical address configuration for the slave modules (central / decentral)	103
5.7	Terminal assignment	104
5.7.1	Terminal assignment PSC1-C-10 (-FBx/-MC)	105
5.7.2	Terminal assignment PSC1-C-10-SDM1 (-FBx/-MC)	107
5.7.3	Terminal assignment PSC1-C-10-SDM2 (-FBx/-MC)	109
5.7.4	Terminal assignment PSC1-E-31	111
5.7.5	Terminal assignment PSC1-E-33	112
5.7.6	Terminal assignment PSC1-E-37 in preparation	114
5.7.7	Terminal assignment PSC1-C-10(-SDMx)-FBx	115
5.8	External 24 VDC power supply	116
5.9	Connection of the external encoder supply	118
5.9.1	Incremental, HTL (on request), SIN/COS, SSI	118
5.10	Connection of the digital inputs	120
5.11	Connection of position and speed sensors	121
5.11.1	General instructions	121
5.11.2	Encoder interface assignment	123
5.11.3	Connection variants	124
5.11.3.1	Connection of an absolute encoder as master	124
5.11.3.2	Connection of an absolute encoder as slave	125
5.11.3.3	Connection of an incremental encoder with TTL signal level	126
5.11.3.4	Connection of a SIN/COS encoder	127
5.11.3.5	Connection of proximity switch PSC1-C-10-SDM1/2	128
5.12	Configuration of the measurement sections	129
5.12.1	General description of the encoder configuration	129
5.12.2	Sensor type	129
5.12.2.1	Absolute encoder	129
5.12.2.2	Incremental encoder	131
5.12.2.3	SineCosine encoder – standard mode	131
5.12.2.4	proximity switches	131
5.12.2.5	Extended monitoring with 2 proximity switches	132

6	RESPONSE TIMES OF THE PSC1	133
6.1	Response times in standard operation	134
6.2	Response times for FAST_CHANNEL	135
6.3	Response times for overspeed distance monitoring	135
6.4	Response times when using the PSC1-E-3x	137
7	COMMISSIONING	139
7.1	Procedure	139
7.2	Sequences for switching on	139
7.3	Reset behaviour.....	140
7.3.1	Reset types and triggering element.....	141
7.3.2	Reset timing.....	142
7.3.3	Reset function.....	142
7.3.3.1	Example reset function with protection against incorrect usage	144
7.4	LED indication.....	147
7.5	Parameter configuration.....	148
7.6	Function test.....	148
7.7	Validation	148
8	SAFETY-RELATED CHECK	149
9	MAINTENANCE	150
9.1	Modification / dealing with changes to the device	150
9.2	Replacement of a module.....	150
9.3	Servicing interval.....	150
10	TECHNICAL DATA	151
10.1	Ambient conditions	151
10.2	Safety-related characteristic data	151
11	SWITCH TYPES	152
12	NOTES FOR DESIGNING, PROGRAMMING, VALIDATING AND TESTING	
	SAFETY-RELATED APPLICATIONS	158
12.1	Risk assessment.....	158
12.2	Technical documentation required.....	160
12.3	Steps required for designing, realisation and testing	161
12.3.1	Phases of the V model	162
12.3.2	Specification of the safety requirements (breakdown)	163
12.3.3	Specification of the functional safety system.....	166
12.3.3.1	Definition of the safety functions.....	166
12.3.3.2	Performance Level required (PLr) (additional emergency stop)	166
12.3.3.3	Example – specification of the safety functions in tabular form	167
12.3.4	Software specification.....	168
12.3.5	Hardware specification	170
12.3.5.1	Selection of SRP/CS and equipment	170
12.3.5.2	Examples for hardware specification.....	171
12.3.5.3	Consideration of systematic failures.....	172
12.3.6	Hardware and software design.....	174
12.3.7	Check on the hardware design.....	174
12.3.7.1	Iterative check on the safety level achieved.....	174
12.3.8	Verification of software (program) and parameters	178
12.3.8.1	FUP check	178
12.3.8.2	Validating FUP against IL and parameters using validation report	181
12.3.9	Performance of system tests / FIT test (Fault Injection Test).....	183

13	APPENDIX	184
13.1	Appendix A – categorisation of the switch types	184
13.2	CE – declaration of conformity.....	189

1 Important notes

Definition of the individual target groups

Designers of safe drive systems:
Engineers and technicians

Mounting, electrical installation, maintenance and device replacement
Industrial electricians and service engineers

Commissioning, operation and configuration:
Technicians and engineers

2 Definitions

The term PSC1 is used as the generic term for all derivatives of the PSC1 product line. If reference is made to a specific derivative in the description, the complete identifier is used.

The term "safe" used in the following refers to categorisation as a safe function for usage up to PL e according to EN ISO 13849-1 or SIL3 according to EN 61508.

The system software "SafePLC2" is used to configure and program the PSC1 modules.

Internally the modules in series PSC1 comprise two independent processing units. These are termed system A and system B in the following.

2.1 Reference documents

<i>Description</i>	<i>Reference</i>
Configuration of the PSC1 module with the "SafePLC2" programming system	Programming manual SafePLC2
Validation report on the parameter configuration implemented and the PLC program	Safety-related test with acceptance report
Acceptance for general safety-related applications	Certificate on the type test for safety control according to Machinery directive 2006/42/EC for product modules PSC1-C-10 PSC1-C-10-MC ⁽¹⁾ PSC1-C-10-FBx ⁽²⁾ PSC1-C-10-SDM1 PSC1-C-10-SDM1-MC ⁽¹⁾ PSC1-C-10-SDM1-FBx ⁽²⁾ PSC1-C-10-SDM2 PSC1-C-10-SDM2-MC ⁽¹⁾ PSC1-C-10-SDM2-FBx ⁽²⁾ PSC1-E-31-12DI-10DIO PSC1-E-33-12DI-6DIO-4RO PSC1-E-37-14DI-4DO-2RO-RIO ⁽³⁾

Options:

- (1) Memory Card to store the configuration, the program and the data; see under:
- (2) For version see: "Optional universal communication interface"
- (3) in preparation

Note:

- Read this manual carefully before you start the installation and commissioning of the PSC1 module.
- Following the documentation is a prerequisite for trouble-free operation and the acceptance of claims under the warranty.

2.2 Abbreviations used

Abbreviation	Meaning
AC	Alternating Current
IL	Instruction List
BGIA (IFA)	Institute for Industrial Safety at the DGUV (German Statutory Accident Prevention Association)
CLK	Here: SSI systems clock
CPU	Central Processing Unit
DC	Direct Current
DIN	Deutsches Institut für Normung
DO	Digital Output
ECFS	EtherCAT Fail Safe; EtherCAT FSoE (Fail Safe over EtherCAT)
EMU EDM	Emergency Monitoring Unit (External Device Monitoring)
EMC	Electro Magnetic Compatibility
EN	European Norm
Encoder	Position measuring system (position, angle)
Encoder interfaces	Electrical connection feature for an individual encoder (rotary encoder or proximity switch)
FW	Firmware; software embedded in electronic devices (embedded software)
G.P.	UL rating; also known as "general use"
HISIDE	Output that switches to positive with 24 VDC nominal level
IFA (BGIA)	Institute for Industrial Safety at the DGUV (German Statutory Accident Prevention Association)
I00..I13	Digital Input
IQIx	Configurable safe digital I/Os; version: Input
IQQx	Configurable safe digital I/Os; version: Output
IPxx	Degree of protection for housing
Ix.y ⁽¹⁾	Digital Input
ISO	International Organisation for Standardisation
LED	Light Emitting Diode
LOSIDE	Output that switches to reference potential
n.a.	not applicable
OLC	Operational Limit Control

Abbreviation	Meaning
PAA	Prozessabbild der Ausgänge (Process image of the outputs)
PAE	Prozessabbild der Eingänge (Process image of the inputs)
PES	Programmable electronic control
Pilot duty	UL Rating
Qx.y ⁽¹⁾	Digital Output
T0,T1	Pulse outputs
TB(1)	T bus connector (backplane bus)
PELV	Protective Extra Low Voltage
PLC	Programmable Logic Controller
SD bus (on request)	Serial diagnostic bus for electronic Schmersal safety switches
SDDC (in preparation)	Safe Device-Device Communication
SELV	Safety Extra Low Voltage
SMMC (on request)	Safe Master-Master Communication
SRP/CS	Safety related parts of a control system
SSI	Synchronous Serial Interface
SW	Software; here: safety-related application software
VDE	Verband der Elektrotechnik, Elektronik und Informationstechnik e. V.
Yx.y ⁽¹⁾	Auxiliary output

⁽¹⁾ Module address x = 0 2
 Channel address y = 0 39

3 Safety instructions

3.1 Intended use

The devices in the series PSC1-C-10 are programmable safety controllers for providing safety shutdown and safety functions. The devices are intended for usage

- In EMERGENCY STOP systems,
- As a safety component in the context of the EC Machinery directive 2006/42/EC,
- As PES for risk reduction in the context of EN 61508,
- In safety circuits according to EN 60204-1 and EN 60204-32,
- As PES for functional safety in the context of EN 62061,
- As SRP/CS in the context of EN ISO 13849,
- As a devices for providing safety functions according to EN 61800-5-2,
- As a logic unit for signal conversion and signal processing in a two-hand circuit according to EN 574.



The devices in series PSC1-C-10 and PSC1-C-10-SDMx incl. the expansion modules PSC1-E-3x are safety components as per Annex IV EC Machinery directive 2006/42/EC.

They have been developed, designed and manufactured according to the above-mentioned directive as well as the EU directive 2014/30/EU

Cf. Appendix EC declaration of conformity

3.2 Usage in regions with UL/CSA requirement

The PSC1 series has a cULus approval with the following standards:

Basic standard(s): UL 61010-1, 3rd Edition, May 11, 2012, Revised July 15 2015,
CAN/CSAC22.2 No. 61010-1-12, 3rd Edition, Revision dated July
2015

Extended standards: UL/CSA 61010-2-201: 2014 (First Edition)

3.3 General safety instructions

Safety instructions:

- To prevent injury and damage, only qualified personnel are allowed to work on the device. Qualified personnel are personnel who have electrical engineering training and who are familiar with the applicable rules and standards of electrical engineering.

The qualified person must become familiar with the operating instructions (cf. IEC364, DIN VDE0100).

- The qualified person must have, as a minimum, detailed knowledge of national health and safety regulations
- The usage of the devices is to be limited to their intended usage as per the list given above. The values in the data listed in section "3.2. Device characteristic data" are also to be met.
- The content of these installation instructions is limited to the basic function of the devices and their installation. The programming of the devices and re-configuration of the device parameters is further described in the "Programming instructions SafePLC2". Detailed knowledge and understanding of this information is a vital prerequisite for a new installation or the modification of the device function or device parameters.
- Commissioning (i.e. commencing operated as intended) is only allowed on compliance with the EMC directive. The EMC test standards EN55011:2007 + A2:2007 and EN 61000-6-2:2005 are used as the basis.
- For storage and transport the conditions according to EN 60068-2-6 in relation to the values stated in "Tech. characteristic data" are to be met
- It is imperative the wiring and connection instructions in the section "Installation" are followed.
- The applicable VDE regulations as well as other special safety regulations for the specific application are to be followed.
- The monitoring functions configured as well as their parameters and operators are to be validated via a validation report.
- The module's implementation is to be agreed with the responsible body (e.g. TÜV or BG).
- Never install or place in operation damaged products. Please report any damage immediately to the transport company.
- Never open the housing and/or make any unauthorised modifications
Inputs and outputs for standard functions and the digital and analogue data transmitted via communication modules are not allowed to be used for safety-related applications.

WARNING:

The usage of our devices contrary to the rules and conditions stated here can result in the injury or the death of persons, as well as damage to the devices and machines connected! This usage will also render void any claim under the warranty or any claim for claim damages against the manufacturer.

3.4 Operating and service

Prior to installing and removing the module, or disconnecting the signal wires, the module is to be electrically isolated. For this purpose all electrically live supply wires to the device are to be switched off and it is to be checked that there is no electrical power present on the wires.

During the installation and removal of the module, appropriate measures are to be taken to prevent electrostatic discharges on the external terminals and connections. Contact with these terminals should therefore remain limited to a minimum; prior to and during this work you should be earthed, e.g. using an earthing wrist strap.

3.5 Transport/storage

The instructions on transport, storage and correct handling are to be followed.
The climatic specifications as per the sec. "Technical data" are to be met.

Device types

The series PSC1-C-10 comprises

- The basic devices PSC1-C-10, PSC1-C-10-SDM1, PSC1-C-10-SDM2
- The expansion modules PSC1-E-31..., PSC1-E-33...
- The decentral (in preparation) expansion module PSC1-E-37...
- The integrated communication interface (optionally with safe fieldbus) PSC1-C-10-...-FBx⁽¹⁾

Basic devices

The series PSC1-C-10 is a compact safety controller with optionally integrated drive monitoring for one (PSC1-C-10-SDM1) or two (PSC1-C-10-SDM2) axes. The device is freely programmable for the safe processing of EMERGENCY STOP buttons, two-hand controls, light barriers, operating mode selector switches, etc. and also drive-related safety functions. For the safety-related signal processing, pre-configured blocks are available for a large number of input devices. The same applies for safety functions for drive monitoring. You will find details in the programming manual.

In the basic version the device has 14 safe inputs and up to 5/3 safe 2-channel shutdown channels. (4x PP or 2x PN semiconductor outputs + 1x 2-channel relay output)

For safe speed and/or position acquisition, 1-encoder solutions and also 2-encoder solutions are supported. See "Encoder specifications"

Expansion modules







Central or decentral (in preparation) I/O expansion for the PSC1-C-10 series.
A maximum of 2 expansion modules can be used.

Integrated communication interface

The communication interface provides bidirectional data transmission from and to a higher-level controller using a standard fieldbus or safe standard fieldbus.

⁽¹⁾For version see: "Optional universal communication interface"

3.6 Module overview

Basic modules			Expansion modules			
Designation	PSC1-C-10(-FBx ⁽¹⁾)	PSC1-C-10-SDM1(-FBx ⁽¹⁾)	PSC1-C-10-SDM2(-FBx ⁽¹⁾)	PSC1-E-31-12DI-10DIO	PSC1-E-33-12DI-6DIO-4RO	PSC1-E-37-14DI-4DO-2RO-RIO ⁽³⁾
						
General data						
Max. number of expansion modules	2*	2*	2*	-	-	-
Safe digital inputs	14	14	14	12	12	14
Safe digital I/O	-	-	-	10	6	-
Safe digital outputs pn switching / pp switching	2/4	2/4	2/4	-	-	2/4
Safe analogue inputs	-	-	-	-	-	-
Relay outputs (1-channel)	2	2	2	-	4	2
Signal outputs	2	2	2	2	2	2
Pulse outputs	2	2	2	2	2	2
Integrated communication interface	FB1 = EtherNet/IP, PROFINET, EtherCAT FB1-PNPS = FB1 + PROFINET + PROFIsafe FB1-ECFS = FB1 + EtherCAT + FSoE FB2 = PROFIBUS, CANopen FB2-PBPS = FB2 + PROFIBUS + PROFIsafe			-	-	-
Axis monitoring	-	1	2	-	-	-
Encoder technology	-	SSI SIN/COS Incr. TTL proximity switches	SSI SIN/COS Incr. TTL proximity switches	-	-	-
Technical data						
See technical characteristic data for the related module						

Options:

- (1) For version see: "Optional universal communication interface"
- (3) in preparation

3.7 Device characteristic data

3.7.1 Basic modules

3.7.1.1 PSC1-C-10 (-FBx⁽¹⁾)/-MC)

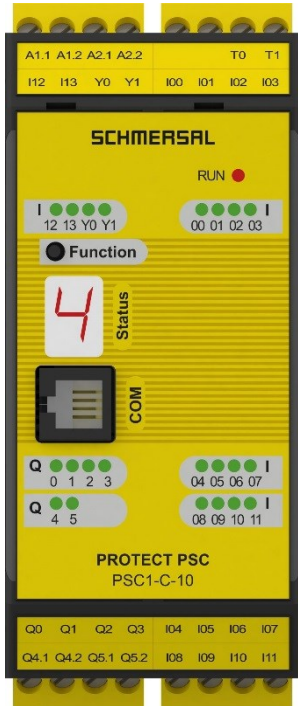
Type designation	Device features
 <p>The image shows the front panel of the SCHMERSAL PSC1-C-10 module. It features a yellow faceplate with a black top section containing terminals labeled A1.1, A1.2, A2.1, A2.2, T0, and T1. Below the terminals are input LEDs labeled I12, I13, Y0, Y1, I00, I01, I02, and I03. The main panel has a 'RUN' indicator, a 7-segment display showing the number '4', a 'Function' button, a 'COM' port, and several groups of status LEDs for inputs (I00-I03, I04-I07, I08-I11) and outputs (Q0-Q3, Q4-Q5). The bottom section has terminals labeled Q0, Q1, Q2, Q3, I04, I05, I06, I07, Q4.1, Q4.2, Q5.1, Q5.2, I08, I09, I10, and I11.</p>	<p>Version of the module with following peripherals:</p> <ul style="list-style-type: none"> 14 digital inputs 2 pulse outputs 2 relay outputs (1-channel) 2/4 pn or pp switching outputs 2 signal outputs 1 diagnostics and configuration interface 1 function button 1 7-segment display 1 status LED 14 status LEDs for inputs 2 status LEDs for signal outputs 2 status LEDs for relay outputs 4 status LEDs for outputs 1 optional: Communication interface incl. Memory card slot (-FBx⁽¹⁾) 1 optional: Memory card slot (-MC)

Properties of the module:

- Can be expanded to:
 - Max. 42 safe digital inputs,
 - Max. 12 safe digital outputs,
 - Max. 20 safe digital I/O,
 - Max. 5 safe relay outputs (2-channel),
 - Max. 6 signal outputs
- Logic processing up to PL e according to EN ISO 13849-1 or SIL 3 according to EN 61508
- Freely programmable small controller for up to 800 IL instructions
- Function plan-orientated programming
- Pulse outputs for cross-circuit detection on digital input signals
- Safety function, external contact monitoring on switchgear connected
- Monitored relay outputs for safety-related functions
- External contact monitoring on switchgear connected (EMU)
- Monitored relay outputs for safety-related functions
- Switchable safe outputs pn, pp switching for safety-related functions
- Parameter administration for expansion modules in the basic device
- Comprehensive diagnostic functions integrated in the firmware
- Coded status indication via 7-segment display and status LEDs on front
- Multi-function button (Quit, Start, Reset) can be operated from the front

- Optional: Communication interface incl. memory card slot
 - Standard and safe fieldbus protocols for communication with a higher-level controller
 - Safe cross-communication for the exchange of data between several basic devices⁽²⁾
 - Safe remote IO communication for the exchange of data with distributed IO systems⁽³⁾
 - Serial diagnostic bus "SD bus" (on request)
 - See: Section 3.7.4 Optional universal communication interface

- Optional: Memory card slot (-MC)
- Mounting on DIN rail
- The mechanical layout of the PSC1-C-10 (-FBx⁽¹⁾/MC) is different to the figure. (See mechanical data)

3.7.1.2 Tech. characteristic data PSC1-C-10 (-FBx⁽¹⁾/MC)

Safety-related characteristic data			
	PL according to EN ISO 13849		max. PL e
	PFH / architecture		12.6 * 10 ⁻⁹ / KAT 4
	SIL according to EN 61508		SIL 3
	Proof test interval		20 years = max. service life
General data			
	Max. number of expansion modules		2
	Interface for expansion modules		T-bus connector, can be plugged into DIN rail
	Number of safe digital inputs		14 (OSSD support)
	Number of safe digital outputs		
	pn switching** or		2
	pp switching **		4
	Number of safe digital I/O		-
	Number of relay outputs (1-channel)		2
	Number of safe analogue inputs		-
	Number of signal outputs		2
	Number of pulse outputs		2
	Type of connection		Removable screw terminals
	Axis monitoring		-
	Encoder interfaces (D-Sub / screw terminal)		-
	Encoder technology (See table Encoder specifications)		-
Electrical data			
	Supply voltage (tolerance)		24 VDC; 2A (-15%, +20%)
	Fuse	A1.1	min. 30 VDC; max. 3,15A
		A1.2	min. 30 VDC; max. 10A
	Max. power consumption (logic)		
	PSC1-C-10		3.1W
	PSC1-C-10 (-FBx ⁽¹⁾)		6.5W
	Rated data digital inputs		24 VDC / 20 mA, type 1 according to EN61131-2
	Rated data digital outputs		
	pn switching		24 VDC; 2A ***
	pp switching		24 VDC; 2A ***
	Signal outputs		24 VDC; 250mA
	Pulse outputs		24 VDC; 250mA
	Rated data relay		
		NO DC13 AC15	24 VDC; 2A 230 VAC; 2A
	Rated data analogue inputs		-
Electrical data (only for UL)			
	Rated data digital outputs		
	pn switching	Temperature rating 30°C	24 VDC; 2A (G.P.)
		Temperature rating 50°C	24 VDC; 1.8A (G.P.)
	pp switching	Temperature rating 30°C	24 VDC; 2A (G.P.)
		Temperature rating 50°C	24 VDC; 1.8A (G.P.)
	Max. cumulative current (pn or pp)		8A
	Auxiliary outputs		24 VDC; 250mA (G.P.)
	Rated data relay	Normally open contact	24 VDC; 2A (Pilot Duty) 120 VAC; 2A (Pilot Duty)

Environmental data		
	Temperature	0°C ... +50°C operation -25°C ... +70°C storage, transport
	Degree of protection	IP 20
	Climatic class	3k3 according to DIN 60 721-3
	Minimum, maximum relative humidity (no condensation)	5% - 85%
	EMC	EN 61000-6-2, EN 61000-6-4, EN 61000-6-7, EN 61800-3, EN 61326-3, EN 62061
	Use of operating equipment	2000m
	Overtoltage category	III
	Level of contamination	2
Mechanical data		
	Size (HxDxW [mm])	PSC1-C-10 = 100x115x45 PSC1-C-10 (-FBx ⁽¹⁾)/-MC) = 100x115x67,5
	Weight	PSC1-C-10 = 300 g PSC1-C-10 (-FBx ⁽¹⁾)/-MC) = 400 g
	Attachment	Can be snapped to DIN rail
	Number of T-bus connector	Included in the items supplied
		PSC1-C-10 = 2
		PSC1-C-10 (-FBx ⁽¹⁾)/MC) = 3
	Min. connection cross-section / AWG	0.2 mm ² / 24
	Max. connection cross-section / AWG	2.5 mm ² / 12

Options:

- ** pn/pp can be configured via SafePLC2
- *** Derating, see section "Derating of outputs"
- (1) For version see: "Optional universal communication interface"
- (2) on request
- (3) in preparation

3.7.1.3 PSC1-C-10-SDM1 (-FBx⁽¹⁾/MC)

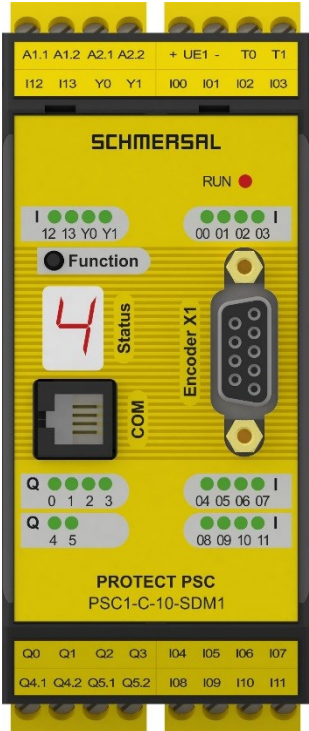
Type designation	Device features
 <p>The image shows the front panel of the PSC1-C-10-SDM1 module. It features a yellow faceplate with the SCHMERSAL logo at the top. Below the logo is a 'RUN' indicator LED. The panel is populated with various components: a 7-segment display showing the number '4', a 'Function' button, a 'Status' LED, and a 'COM' port. There are two 'Encoder X1' ports. The top and bottom edges have terminal blocks for digital inputs (A1.1-A2.2, I12-I13, Y0-Y1, I00-I03) and digital outputs (Q0-Q3, Q4-Q5, I04-I07, Q4.1-Q5.2, I08-I11). A 'PROTECT PSC PSC1-C-10-SDM1' label is visible at the bottom of the faceplate.</p>	<p>Version of the module with following peripherals:</p> <ul style="list-style-type: none"> 1 axis 3 encoder interfaces 14 digital inputs 2 pulse outputs 2 relay outputs (1-channel) 2/4 pn or pp switching outputs 2 signal outputs 1 diagnostics and configuration interface 1 function button 1 7-segment display 1 status LED 14 status LEDs for inputs 2 status LEDs for signal outputs 2 status LEDs for relay outputs 4 status LEDs for outputs 1 optional: Communication interface (-FBx⁽¹⁾)

Properties of the module:

- Can be expanded to:
 - Max. 42 safe digital inputs,
 - Max. 12 safe digital outputs,
 - Max. 20 safe digital I/O,
 - Max. 5 safe relay outputs (2-channel),
 - Max. 6 signal outputs,
 - Max. 1 safe axis
- Logic processing up to PL e EN ISO 13849-1 or SIL 3 as per EN 61508
- Movement monitoring on one axis up to PL e EN ISO 13849-1 or SIL 3 as per EN 61508
 - Velocity monitoring
 - Speed monitoring
 - Standstill monitoring
 - Direction of rotation monitoring
 - Safe increment
 - Emergency stop monitoring
 - Position monitoring
 - Position range monitoring
 - Movement range monitoring
 - Destination position monitoring
- Freely programmable small controller for up to 800 IL instructions
- Function plan-orientated programming
- Pulse outputs for cross-circuit detection on digital input signals
- Counter inputs alternative to the digital inputs
- External contact monitoring on switchgear connected (EMU)
- Monitored relay outputs for safety-related functions

- Switchable safe outputs pn, pp switching for safety-related functions
- Complete speed and position-related safety functions for drive monitoring as per IEC 61800-5-2 integrated into firmware
 - Spatial functions for safe speed and range monitoring possible
- Parameter administration for expansion modules in the basic device
- Comprehensive diagnostic functions integrated
- Coded status indication via 7-segment display and status LEDs on front
- Multi-function button (Quit, Start, Reset) can be operated from the front
- Optional: Universal communication interface
 - Standard and safe fieldbus protocols for communication with a higher-level controller
 - Safe cross-communication (SMMC) for the exchange of data between several basic devices⁽²⁾
 - Safe remote IO communication for the exchange of data with distributed IO systems⁽³⁾
 - Serial diagnostic bus "SD bus" (on request)

See: Section 3.2.4.3 Optional universal communication interface
- Mounting on DIN rail
- The mechanical layout of the PSC1-C-10 (-FBx⁽¹⁾/MC) is different to the figure. (See mechanical data)

3.7.1.4 Tech. characteristic data PSC1-C-10-SDM1 (-FBx⁽¹⁾/MC)

Safety-related characteristic data				
	PL according to EN ISO 13849	PL e		
	PFH / architecture	12.6 * 10 ⁻⁹ / KAT 4		
	SIL according to EN 61508	SIL 3		
	Proof test interval	20 years = max. service life		
General data				
	Max. number of expansion modules	2		
	Interface for expansion modules	T-bus connector, can be plugged into DIN rail		
	Number of safe digital inputs	14 (OSSD support)		
	Number of safe digital outputs			
	pn switching **	2		
	pp switching **	4		
	Number of safe digital I/O	-		
	Number of relay outputs (1-channel)	2		
	Number of safe analogue inputs	-		
	Number of signal outputs	2		
	Number of pulse outputs	2		
	Type of connection	Removable screw terminals		
	Axis monitoring	1		
	Encoder interfaces (D-Sub / screw terminals)	1 / 2 (*)		
	Encoder technology (See table Encoder specifications)	SSI, SinCos, TTL, proximity switch		
Electrical data				
	Supply voltage (tolerance)	24 VDC; 2A (-15%, +20%)		
	Fuse	A1.1	min. 30 VDC; max. 3,15A	
		A1.2	min. 30 VDC; max. 10A	
	Max. power consumption (logic)			
		PSC1-C-10-SDM1	3.1W	
		PSC1-C-10-SDM1 (-FBx ⁽¹⁾)	6.5W	
	Rated data digital inputs	24 VDC / 20 mA, type 1 according to EN61131-2		
	Rated data digital outputs			
		pn switching	24 VDC; 2A ***	
		pp switching	24 VDC; 2A ***	
		Signal outputs	24 VDC; 250mA	
		Pulse outputs	24 VDC; 250mA	
	Rated data relay			
		NO	24 VDC; 2A	
		DC13 AC15	230 VAC; 2A	
	Rated data analogue inputs	-		
Electrical data (only for UL)				
	Rated data digital outputs			
	pn switching	Temperature rating 30°C	24 VDC; 2A (G.P.)	
		Temperature rating 50°C	24 VDC; 1.8A (G.P.)	
		pp switching	Temperature rating 30°C	24 VDC; 2A (G.P.)
			Temperature rating 50°C	24 VDC; 1.8A (G.P.)
	Max. cumulative current (pn or pp)		8A	
	Auxiliary outputs		24 VDC; 250mA (G.P.)	
	Rated data relay	Normally open contact	24 VDC; 2A (Pilot Duty) 120 VAC; 2A (Pilot Duty)	
Environmental data				
	Temperature	0°C ... +50°C operation -25°C ... +70°C storage, transport		
	Degree of protection	IP 20		
	Climatic class	3k3 according to DIN 60 721-3		
	Minimum, maximum relative humidity (no condensation)	5% - 85%		
	EMC	EN 61000-6-2, EN 61000-6-4, EN 61000-6-7, EN 61800-3, EN 61326-3, EN 62061		
	Use of operating equipment	2000m		
	Overvoltage category	III		
	Level of contamination	2		
Mechanical data				
	Size (HxDxW [mm])	PSC1-C-10-SDM1	= 100x115x45	

		PSC1-C-10-SDM1 (-FBx ⁽¹⁾ /MC)= 100x115x67,5
Weight		PSC1-C-10-SDM1 = 310 g PSC1-C-10-SDM1 (-FBx ⁽¹⁾) = 410 g
Attachment		Can be snapped to DIN rail
Number of T-bus connector		Included in the items supplied
	PSC1-C-10-SDM1	2
	PSC1-C-10-SDM1 (-FBx ⁽¹⁾ /MC)	3
Min. connection cross-section / AWG		0.2 mm ² / 24
Max. connection cross-section / AWG		2.5 mm ² / 12

Options;

- * Maximum 2 encoders / axis
- ** pn/pp can be configured via SafePLC2
- *** Derating, see section "Derating of outputs"
- (1) For version see: "Optional universal communication interface"
- (2) on request
- (3) in preparation

3.7.1.5 PSC1-C-10-SDM2 (-FBx⁽¹⁾/MC)

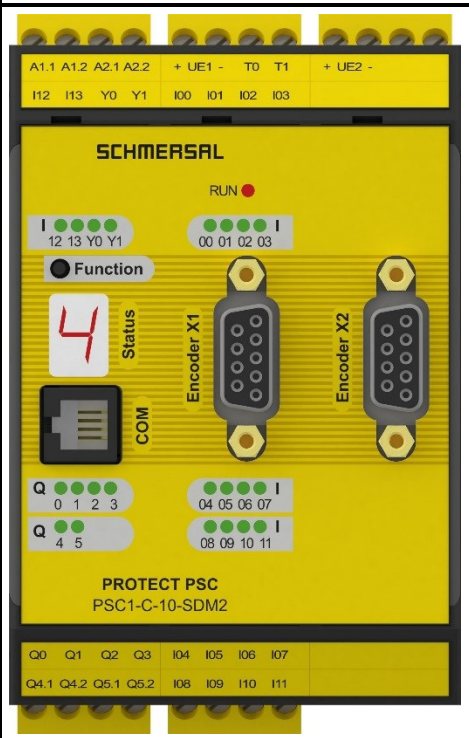
Type designation	Device features
 <p>The image shows the front panel of the PSC1-C-10-SDM2 module. It features a yellow top section with terminal blocks for inputs (A1.1-A2.2, I12-I13, Y0-Y1, I00-I01, I02-I03) and outputs (+UE1-, T0, T1, +UE2-). Below this is a central area with a 7-segment display showing the number '4', a 'Function' button, a 'Status' LED, and two D-sub encoder interfaces labeled 'Encoder X1' and 'Encoder X2'. There are also several groups of status LEDs for inputs (I12-I13, Y0-Y1, I00-I01, I02-I03), outputs (Q0-Q3, Q4-Q5, I04-I05, I06-I07, I08-I09, I10-I11), and a 'COM' port. The bottom section has terminal blocks for outputs (Q0-Q3, I04-I05, I06-I07, Q4.1-Q4.2, Q5.1-Q5.2, I08-I09, I10-I11). The text 'SCHMERSAL' and 'PROTECT PSC PSC1-C-10-SDM2' are printed on the panel.</p>	<p>Version of the module with following peripherals:</p> <ul style="list-style-type: none"> 2 axes 4 encoder interfaces 14 digital inputs 2 pulse outputs 2 relay outputs (1-channel) 2/4 pn or pp switching outputs 2 signal outputs 1 diagnostics and configuration interface 1 function button 1 7-segment display 1 status LED 14 status LEDs for inputs 2 status LEDs for signal outputs 2 status LEDs for relay outputs 4 status LEDs for outputs 1 optional: Communication interface (-FBx⁽¹⁾)

Properties of the module:

- Can be expanded to:
 - Max. 42 safe digital inputs,
 - Max. 12 safe digital outputs,
 - Max. 20 safe digital I/O,
 - Max. 5 safe relay outputs (2-channel),
 - Max. 6 signal outputs,
 - Max. 2 safe axes
- Logic processing up to PL e EN ISO 13849-1 or SIL 3 as per EN 61508
- Movement monitoring on one or two axes up to PL e EN ISO 13849-1 or SIL 3 as per EN 61508
 - Velocity monitoring
 - Speed monitoring
 - Standstill monitoring
 - Direction of rotation monitoring
 - Safe increment
 - Emergency stop monitoring
 - Position monitoring
 - Position range monitoring
 - Movement range monitoring
 - Destination position monitoring
- Freely programmable small controller for up to 800 IL instructions
- Function plan-orientated programming
- Pulse outputs for cross-circuit detection on digital input signals
- Counter inputs alternative to the digital inputs
- External contact monitoring on switchgear connected (EMU)
- Monitored relay outputs for safety-related functions

- Switchable safe outputs pn, pp switching for safety-related functions
- Parameter administration for expansion modules in the basic device
- Comprehensive diagnostic functions integrated
- Coded status indication via 7-segment display and status LEDs on front
- Multi-function button (Quit, Start, Reset) can be operated from the front
- Optional: Universal communication interface
 - Standard and safe fieldbus protocols for communication with a higher-level controller
 - Safe cross-communication (SMMC) for the exchange of data between several basic devices⁽²⁾
 - Safe remote IO communication for the exchange of data with distributed IO systems⁽³⁾
 - Serial diagnostic bus "SD bus" (on request)See: Section 3.2.4.3 Optional universal communication interface
- Mounting on DIN rail
- Expanded functionality:
 - Permits the connection of 2 rotary encoders per axis (SSI, Sin/Cos, TTL)
- The mechanical layout of the PSC1-C-10-SDM2 (-FBx⁽¹⁾/MC) is different to the figure. (See mechanical data)

3.7.1.6 Tech. characteristic data PSC1-C-10-SDM2 (-FBx⁽¹⁾)

Safety-related characteristic data		
	PL according to EN ISO 13849	PL e
	PFH / architecture	12.6 * 10 ⁻⁹ / KAT 4
	SIL according to EN 61508	SIL 3
	Proof test interval	20 years = max. service life
General data		
	Max. number of expansion modules	2
	Interface for expansion modules	T-bus connector, can be plugged into DIN rail
	Number of safe digital inputs	14 (OSSD support)
	Number of safe digital outputs	
	pn switching **	2
	pp switching **	4
	Number of safe digital I/O	-
	Number of relay outputs (1-channel)	2
	Number of safe analogue inputs	-
	Number of signal outputs	2
	Number of pulse outputs	2
	Type of connection	Removable screw terminals
	Axis monitoring	2
	Encoder interfaces (D-Sub / screw terminals)	2 / 2 (*)
	Encoder technology (See table Encoder specifications)	SSI, SinCos, TTL, proximity switch
Electrical data		
	Supply voltage (tolerance)	24 VDC; 2A (-15%, +20%)
	Fuse	A1.1 min. 30 VDC; max. 3,15A A1.2 min. 30 VDC; max. 10A
	Max. power consumption (logic)	
	PSC1-C-10-SDM2	3.1W
	PSC1-C-10-SDM2 (-FBx ⁽¹⁾)	6.7W
	Rated data digital inputs	24 VDC / 20 mA, type 1 according to EN61131-2
	Rated data digital outputs	
	pn switching	24 VDC; 2A ***
	pp switching	24 VDC; 2A ***
	Signal outputs	24 VDC; 250mA
	Pulse outputs	24 VDC; 250mA
	Rated data relay	
	NO DC13 AC15	24 VDC; 2A 230 VAC; 2A
	Rated data analogue inputs	-
Electrical data (only for UL)		
	Rated data digital outputs	
	pn switching	Temperature rating 30°C 24 VDC; 2A (G.P.) Temperature rating 50°C 24 VDC; 1.8A (G.P.)
	pp switching	Temperature rating 30°C 24 VDC; 2A (G.P.) Temperature rating 50°C 24 VDC; 1.8A (G.P.)
	Max. cumulative current (pn or pp)	8A
	Auxiliary outputs	24 VDC; 250mA (G.P.)
	Rated data relay	Normally open contact 24 VDC; 2A (Pilot Duty) 120 VAC; 2A (Pilot Duty)
Environmental data		
	Temperature	0°C ... +50°C operation -25°C ... +70°C storage, transport
	Degree of protection	IP 20
	Climatic class	3k3 according to DIN 60 721-3
	Minimum, maximum relative humidity (no condensation)	5% - 85%
	EMC	EN 61000-6-2, EN 61000-6-4, EN 61000-6-7, EN 61800-3, EN 61326-3, EN 62061
	Use of operating equipment	2000m
	Overvoltage category	III
	Level of contamination	2
Mechanical data		
	Size (HxDxW [mm])	PSC1-C-10-SDM2 = 100x115x67,5 PSC1-C-10-SDM2 (-FBx ⁽¹⁾ /MC)= 100x115x90

	Weight	PSC1-C-10-SDM2 = 390 g PSC1-C-10-SDM2 (-FBx ⁽¹⁾ /MC) = 490 g	
	Attachment	Can be snapped to DIN rail	
	Number of T-bus connector	Included in the items supplied	
		PSC1-C-10-SDM2	3
		PSC1-C-10-SDM2 (-FBx ⁽¹⁾ /MC)	4
	Min. connection cross-section / AWG	0.2 mm ² / 24	
	Max. connection cross-section / AWG	2.5 mm ² / 12	

Options:

- * Maximum 2 encoders / axis
- ** pn/pp can be configured via SafePLC2
- *** Derating, see section "Derating of outputs"
- (1) For version see: "Optional universal communication interface"
- (2) on request
- (3) in preparation

3.7.2 Central expansion modules

3.7.2.1 PSC1-E-31 and PSC1-E-33

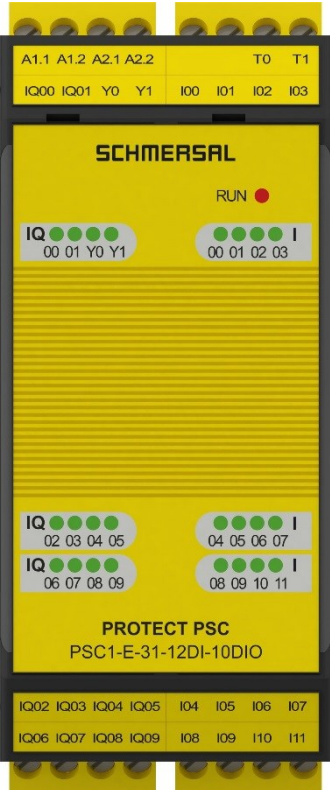
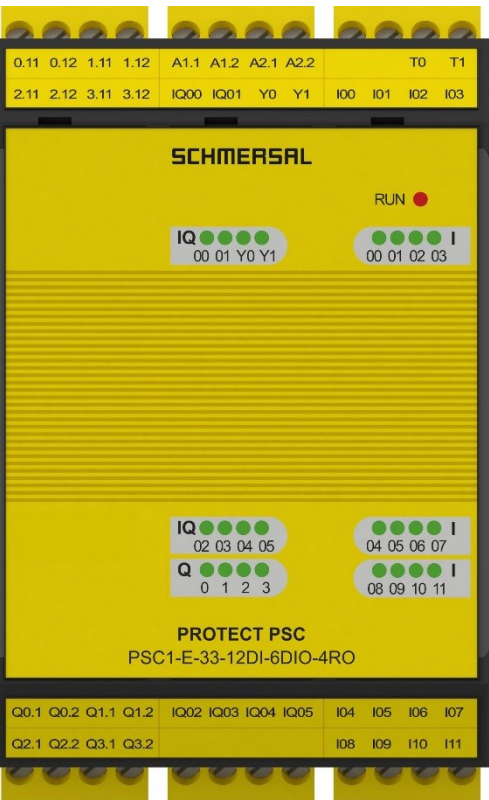
Type designation	Device features
 <p>The image shows the front panel of a yellow SCHMERSAL PSC1-E-31-12DI-10DIO module. At the top, there are two rows of terminal labels: A1.1, A1.2, A2.1, A2.2, T0, T1 and IQ00, IQ01, Y0, Y1, IO0, IO1, IO2, IO3. The main panel features a 'RUN' indicator light and two sets of status LEDs: 'IQ' (00-01, Y0, Y1) and 'I' (00, 01, 02, 03). Below these are two more sets of LEDs: 'IQ' (02, 03, 04, 05) and 'I' (04, 05, 06, 07), and another set: 'IQ' (06, 07, 08, 09) and 'I' (08, 09, 10, 11). The bottom of the panel is labeled 'PROTECT PSC PSC1-E-31-12DI-10DIO'. At the very bottom, there are two rows of terminal labels: IQ02, IQ03, IQ04, IQ05, IO4, IO5, IO6, IO7 and IQ06, IQ07, IQ08, IQ09, IO8, IO9, IO10, IO11.</p>	<p>Version of the module with following peripherals:</p> <ul style="list-style-type: none"> 12 digital inputs 10/6 digital I/O 2 pulse outputs 2 signal outputs 0/4 relay outputs (1-channel) (PSC1-E-31/33) 12 status LEDs for inputs 2 status LEDs for signal outputs 0/4 status LEDs for relay outputs (PSC1-E-31/33) 10/6 status LEDs for I/O (PSC1-E-31/33)
 <p>The image shows the front panel of a yellow SCHMERSAL PSC1-E-33-12DI-6DIO-4RO module. At the top, there are three rows of terminal labels: 0.11, 0.12, 1.11, 1.12, A1.1, A1.2, A2.1, A2.2, T0, T1; 2.11, 2.12, 3.11, 3.12, IQ00, IQ01, Y0, Y1, IO0, IO1, IO2, IO3; and a blank row. The main panel features a 'RUN' indicator light and two sets of status LEDs: 'IQ' (00-01, Y0, Y1) and 'I' (00, 01, 02, 03). Below these are two sets of LEDs: 'IQ' (02, 03, 04, 05) and 'I' (04, 05, 06, 07), and another set: 'Q' (0, 1, 2, 3) and 'I' (08, 09, 10, 11). The bottom of the panel is labeled 'PROTECT PSC PSC1-E-33-12DI-6DIO-4RO'. At the very bottom, there are two rows of terminal labels: Q0.1, Q0.2, Q1.1, Q1.2, IQ02, IQ03, IQ04, IQ05, IO4, IO5, IO6, IO7 and Q2.1, Q2.2, Q3.1, Q3.2, IO8, IO9, IO10, IO11.</p>	

Properties of the module:

- 12 safe inputs, OSSD support
- 10 safe I/O - can be configured as input or output
 - PSC1-E-33 with a total of 4 relay outputs (1- channel) and 6 I/O
- Pulse outputs for cross-circuit detection on digital input signals
- External contact monitoring on switchgear connected (EMU)
- Contact multiplication or contact rating increase by means of external contactors in conjunction with integrated monitoring possible
- Comprehensive diagnostic functions integrated in the firmware
- Power supply via basic module
- Mounting on DIN rail

3.7.2.2 Tech. characteristic data: PSC1-E-31 and PSC1-E-33

Safety-related characteristic data			
	PL according to EN ISO 13849	PL e	
	PFH / architecture	$9,2 \cdot 10^{-9}$ / KAT 4 ⁽¹⁾ + on PSC1-E-33 1-channel per relay $2 \cdot 10^{-8}$ (KAT 1) 2-channel per relay $1 \cdot 10^{-9}$ (KAT 4)	
	SIL according to EN 61508	SIL 3	
	Proof test interval	20 years = max. service life	
General data			
	Max. number of expansion modules	-	
	Interface for expansion modules	T-bus connector, can be plugged into DIN rail	
	Number of safe digital inputs	12 (OSSD support)	
	Number of safe digital outputs	-	
	Number of safe digital I/O		
	PSC1-E-31	10	
	PSC1-E-33	6	
	Number of relay outputs (1-channel)	-	
	PSC1-E-31	-	
	PSC1-E-33	4	
	Number of safe analogue inputs	-	
	Number of signal outputs	2	
	Number of pulse outputs	2	
	Type of connection	Removable screw terminals	
	Axis monitoring	-	
	Encoder interfaces (D-Sub / screw terminals)	-	
	Encoder technology (See table Encoder specifications)	-	
Electrical data			
	Supply voltage (tolerance)	24 VDC; 2A (-15%, +20%)	
	Fuse A1.1	30 VDC/ 10 A	
	Max. power consumption (logic)	7.1 W	
	Rated data digital inputs	24 VDC / 20 mA, type 1 according to EN61131-2	
	Rated data digital outputs		
	Signal outputs	24 VDC; 250mA	
	Pulse outputs	24 VDC; 250mA	
	Digital I/O 00 – 04	24 VDC; 0.5A	
	05 – 09	24 VDC; 2A ***	
	Rated data relay	-	
	NO DC13	24 VDC; 2A	
	AC15	230 VAC; 2A	
	NC (readback contact) DC13	24 VDC; 2 A	
	Rated data analogue inputs	-	
Electrical data (only for UL)			
	Rated data digital outputs		
	Auxiliary outputs	24 VDC; 250mA (G.P.)	
	Digital I/O00 – 04	24 VDC; 0.5A (G.P.)	
	05 – 09	Temperature rating 30°C	24 VDC; 2A (G.P.)
		Temperature rating 50°C	24 VDC; 1.8A (G.P.)
	Max. cumulative current	10A	
	Rated data relay		
	Normally open contact	24 VDC; 2A (Pilot Duty) 120 VAC; 2A (Pilot Duty)	
	Normally closed (readback contact)	24 VDC; 2A (Pilot Duty)	
Environmental data			
	Temperature	0°C ... +50°C operation -25°C ... +70°C storage, transport	
	Degree of protection	IP 20	
	Climatic class	3k3 according to DIN 60 721-3	
	Minimum, maximum relative humidity (no condensation)	5% - 85%	
	EMC	EN 61000-6-2, EN 61000-6-4, EN 61000-6-7, EN 61800-3, EN 61326-3, EN 62061	
	Use of operating equipment	2000m	
	Overvoltage category	III	
	Level of contamination	2	

Mechanical data		
Size (HxDxW [mm])	PSC1-E-31	= 100x115x45
	PSC1-E-33	= 100x115x67,5
Weight	PSC1-E-31	= 300 g
	PSC1-E-33	= 400 g
Attachment	Can be snapped to DIN rail	
Number of T-bus connector	Included in the items supplied	
	PSC1-E-31	2
	PSC1-E-33	3
Min. connection cross-section / AWG	0.2 mm ² / 24	
Max. connection cross-section / AWG	2.5 mm ² / 12	

Options:

*** Derating, see section "Derating of outputs"

¹⁾Value only applies for expansion module. For an overall assessment according to EN 13849 a series connection with the related basic device is to be used

$$\Rightarrow PFH_{Logic} = PFH_{Basic} + PFH_{Expansion}$$

3.7.3 Decentralised expansion modules (in preparation)

3.7.3.1 PSC1-E-37

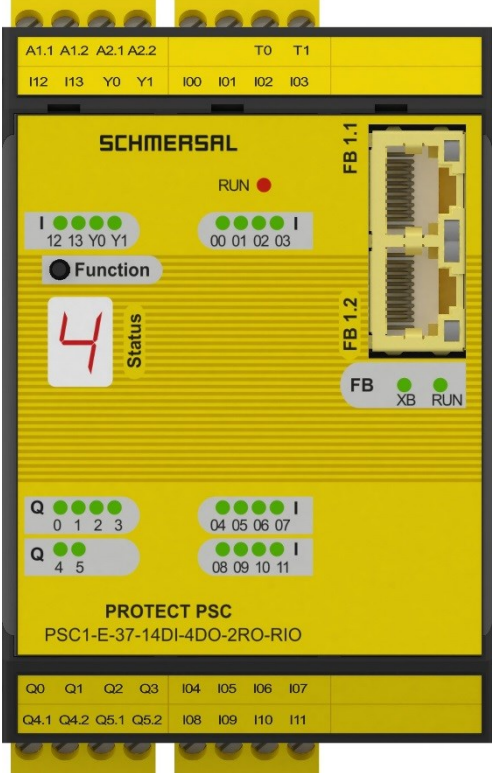
Type designation	Device features
 <p>The image shows the front panel of the SCHMERSAL PSC1-E-37 module. It features a yellow faceplate with various components: terminal blocks at the top and bottom labeled with alphanumeric codes (A1.1-A2.2, I12-I13, Y0-Y1, I00-I03, T0-T1, Q0-Q3, I04-I07, Q4.1-Q5.2, I08-I11); a central display area with a 7-segment display showing the number '4', a 'Function' button, and several LED indicators; two fiber optic ports labeled 'FB 1.1' and 'FB 1.2'; and a 'PROTECT PSC' label with the model number 'PSC1-E-37-14DI-4DO-2RO-RIO'.</p>	<p>Version of the module with following peripherals:</p> <ul style="list-style-type: none"> 14 digital inputs 2 pulse outputs 2 relay outputs (1-channel) 2/4 pn or pp switching outputs 2 signal outputs 1 7-segment display 1 status LED 2 status LEDs for signal outputs 14 status LEDs for inputs 2 status LEDs for relay outputs 4 status LEDs for outputs

Properties of the module:

- 14 safe inputs, OSSD support
- Cross-circuit monitoring
- Contact multiplication or contact rating increase by means of external contactors in conjunction with integrated monitoring possible
- Comprehensive diagnostic functions integrated in the firmware
- Mounting on DIN rail

3.7.3.2 Tech. characteristic data: PSC1-E-37

Safety-related characteristic data				
	PL according to EN ISO 13849		PL e	
	PFH / architecture		$12,6 * 10^{-9}$ / KAT 4 ⁽¹⁾	
	SIL according to EN 61508		SIL 3	
	Proof test interval		20 years = max. service life	
General data				
	Connection		RJ45 (SDDC)	
	Number of safe digital inputs		14 (OSSD support)	
	Number of safe digital outputs			
	pn switching **		2	
	pp switching **		4	
	Number of safe digital I/O		-	
	Number of relay outputs (1-channel)		2	
	Number of safe analogue inputs		-	
	Number of signal outputs		2	
	Number of pulse outputs		2	
	Type of connection		Removable screw terminals	
	Axis monitoring		-	
	Encoder interfaces (D-Sub / screw terminal)		-	
	Encoder technology (See table Encoder specifications)		-	
Electrical data				
	Supply voltage (tolerance)		24 VDC; 2A (-15%, +20%)	
	Fuse	A1.1	min. 30 VDC; max. 3,15A	
		A1.2	min. 30 VDC; max. 10A	
	Max. power consumption (logic)			
	PSC1-E-37		6.5W	
	Rated data digital inputs		24 VDC / 20 mA, type 1 according to EN61131-2	
	Rated data digital outputs			
		pn switching	24 VDC; 2A ***	
		pp switching	24 VDC; 2A ***	
		Signal outputs	24 VDC; 250mA	
		Pulse outputs	24 VDC; 250mA	
	Rated data relay			
		NO DC13 AC15	24 VDC; 2A 230 VAC; 2A	
	Rated data analogue inputs		-	
Electrical data (only for UL)				
	Rated data digital outputs			
		pn switching	Temperature rating 30°C	24 VDC; 2A (G.P.)
			Temperature rating 50°C	24 VDC; 1.8A (G.P.)
		pp switching	Temperature rating 30°C	24 VDC; 2A (G.P.)
			Temperature rating 50°C	24 VDC; 1.8A (G.P.)
		Max. cumulative current (pn or pp)	8A	
		Auxiliary outputs	24 VDC; 250mA (G.P.)	
	Rated data relay	Normally open contact	24 VDC; 2A (Pilot Duty) 120 VAC; 2A (Pilot Duty)	

Environmental data		
	Temperature	0°C ... +50°C operation -25°C ... +70°C storage, transport
	Degree of protection	IP 20
	Climatic class	3k3 according to DIN 60 721-3
	Minimum, maximum relative humidity (no condensation)	5% - 85%
	EMC	EN 61000-6-2, EN 61000-6-4, EN 61000-6-7, EN 61800-3, EN 61326-3, EN 62061
	Use of operating equipment	2000m
	Overvoltage category	III
	Level of contamination	2
Mechanical data		
	Size (HxDxW (mm))	PSC1-E-37 = 100x115x67,5
	Weight	PSC1-E-37 = 400 g
	Attachment	Can be snapped to DIN rail
	Min. connection cross-section / AWG	0.2 mm ² / 24
	Max. connection cross-section / AWG	2.5 mm ² / 12

Options:

** pn/pp can be configured via SafePLC2

*** Derating, see section "Derating of outputs"

¹⁾Value only applies for expansion module. For an overall assessment according to EN 13849 a series connection with the related basic device is to be used

$$\Rightarrow PFH_{Logic} = PFH_{Basic} + PFH_{Expansion} + PFH_{SDDC/SMMC}$$

Note:

If the network architecture consists of only one basic module and decentralised I/O modules, a PFH_{SDDC} value of $2.2 \cdot 10^{-9}$ must be added.

In this context, the number of decentralised I/O modules has no influence on the PFD value.

If the network architecture consists of several basic modules and decentralised I/O modules, a $PFH_{SDDC/SMMC}$ value of $3.2 \cdot 10^{-9}$ must be added.

3.7.4 Optional universal communication interface

Version	Device features
-FB1	Decentral SDDC ⁽²⁾ and SMMC ⁽¹⁾ interface (2x RJ 45) Communication interface for decentral slave and master modules Fieldbus interface (2x RJ 45) Standard and secure fieldbus Memory Card (microSD) Storage medium for safety-related user program
-FB2	Decentral SDDC ⁽²⁾ and SMMC ⁽¹⁾ interface (2x RJ 45) Communication interface for decentral slave and master modules Fieldbus interface (Sub-D) Standard and secure fieldbus Memory Card (microSD) Storage medium for safety-related user program

Options:

- (1) on request
- (2) in preparation

Properties of the universal communication interface:

- Optional version of the communication interface for the PSC1 series
- The different versions can be combined. See "Possible combinations".
- For more detailed information, please refer to the installation manuals for the related fieldbus modules.

3.7.4.1 Tech. characteristic data: Optional universal communication interface

Safety-related characteristic data		
	PL according to EN ISO 13849	n.a.
	PFH / architecture	n.a.
	SIL according to EN 61508	n.a.
	Proof test interval	n.a.
General data		
	Decentral communication interfaces (SDDC in preparation)	2x RJ 45*
	Fieldbus interfaces	
	-FB1	2x RJ 45**
	-FB2	1x Sub-D***
	Memory Card (safety program)	1x microSD (front side)
	SD bus (on request)	Connector (with screw terminals)
	Status LEDs	4
	Fieldbus address rotary switches	
	-FB2	2
Electrical data		
	Power consumption (SD bus)	3.6 W
Environmental data		
	Temperature	0° ... +50° C operating temp.; -25C° ... +70C° storage, transport
	Degree of protection	IP 20
	Climatic class	3k3 according to DIN 60 721
	EMC	Corresponding to EN 55011 and EN 61000-6-2
Mechanical data		
	Size (HxDxW [mm])	100x115x22.5
	Attachment	Can be snapped to DIN rail
	Number of T-bus	Included in the items supplied
	Min. connection cross-section / AWG	0.2 mm ² / 24
	Max. connection cross-section / AWG	2.5 mm ² / 12

Options

- * Optionally for SDDC or SMMC (on request)
- ** Available fieldbuses EtherNet/IP, PROFINET and EtherCAT
- *** Available fieldbuses PROFIBUS, CANopen

3.7.4.2 Possible combinations

FBx module is built into the following devices and not available separately.

		Versions			
		-FB1	-FB2	SDDC ⁽¹⁾	SMMC ⁽²⁾
Module type	PSC1-C-10	x	x	x	x
	PSC1-C-10-SDM1	x	x	x	x
	PSC1-C-10-SDM2	x	x	x	x
	PSC1-E-31				
	PSC1-E-33				
	PSC1-E-37			x	

Options:

- (1) (in preparation) / always with option -FB1/2 or integrated in the module PSC1-E-37
 (2) (on request) / always with option -FB1/2

3.7.4.3 Using the memory card

Any industrial microSD card between 2 MB and 16 GB may be used with FAT16 or FAT32 file system.

The safety-related application program with its parameters, also called "configuration", and the "network configuration" is created with the SafePLC2 programming system. The two configurations must be renamed before they are copied to the memory card in a folder "bin", which must be created in the root directory.

Project configuration	
<i>Sampleproject.cfg2</i>	config.cfd

Network configuration	
<i>Sampleproject.cfdNetwork</i>	network.cfd

After the copying process has been completed, the card can be inserted into the slot at the front.

Now switch the supply voltage off and on again.

After booting, the system generates the alarm "A01212", an indication that there are different configurations in the system and on the card. If the configurations are the same, the known boot sequence runs.

Now press the function button on the front twice within 3 seconds.

The system now switches to stop status. A "5" appears in the 7-segment display. The entire configuration including the network configuration has now been transferred from the card to the security control system.

When using an FB1 or FB2 option, LED 2 flashes rapidly. The system is started automatically with this configuration.

3.7.5 Encoder specifications

Encoder type	Connection	Diagnostics	Value
SIN/COS; TTL			
	X1; X2	Max. frequency	200 kHz
		Amplitude SIN/COS	1 V _{ss} +/- 0,3 V
		Type of connection	Sub-D 9-pin
SSI absolute			
	X1; X2	Clock frequency	Master mode 150 kHz / slave mode max. 250 kHz
		Max. frame length / data length	32 / 28 bits
		Pos. user data	Adjustable
		Type of connection	Sub-D 9-pin
Proximity switch / HTL			
	I04 – I07	Max. frequency	10 kHz (Proxy 2 only 4 kHz, see 5.12.2.5)
		Type of connection	Removable screw terminal

3.8 Derating outputs

Maximum current carrying capacity based on temperature.

This "derating" must be taken into account for all 2A outputs (IO board and REL board)!

At an ambient temperature of **up to 30°C** the 2A outputs may be fully loaded.

From an ambient temperature of **30°C** to a maximum of **50°C**, the 2A outputs may only be loaded up to a maximum of **1.8A** and the total current may not exceed **10A**.

3.9 Marking

The type plate is attached to the left side wall of the module and contains the following information:

3.9.1 Type plate

- Type designation
- Part number/item number
- Serial number
- Hardware release identifier
- Software release identifier
- Safety category
- Properties of the power supply
- Properties of the inputs
- Properties of the outputs
- Date of manufacture (CW/year)
- UL relevant data
- Strings between "*" and "#" represent bar codes

*103008441-123456#		Date: 3C9/2017
Product No.: 103008445	Serial No.: 123456	
*07A-07C-04A-04A-03A#	MAC: 14-C3-C2-01-XX-XX	
HW-Release: 11-11-07	FW-Rel.COM1: 01-05-02	
FW-Release: 05-00-00-05	FW-Rel.COM2: 01-03-01	
*02-01-00-06#		
Type: PSC1-C-10-SDM1-FB1		
NORM:	SIL 3:	IEC 61508 / IEC 62061
	Cat. 4 / PL e:	EN ISO 13849-1
Power:	A1.1 - A1.3:	24 VDC / -15%...+20% / 0...50°C
	A1.1 / 2 / 3:	2 A / 9 A / 0,25 A
INPUT:	I00...I13 (Digital):	24 VDC
OUTPUT:	Q0...Q3 (Digital):	24 VDC / 2 A
	Q4...Q5 (Relay):	240 VAC / 24 VDC / 2 A
	Y0...Y1 (Auxiliary):	24 VDC / 0,25 A

 LISTED E304506 IND.CONT.EQ.	Main supply: 24 V~, SELV/PELV;	 
	Power consumption: 24 V~ / 2 A; OUTPUT (general use):	
	- Digital: Q0-Q3 24 V~ / 2 A, max. total current: 8 A;	
	- Auxiliary: 24 V~ / 250 mA;	
	- Relay NO (plot duty): 24 V~ / 2 A; 120 V~ / 2 A	

K.A. Schmersal GmbH & Co. KG, DE-42279 Wuppertal
 Möddinghofe 30 www.schmersal.com Read manual before installation!

Type plate PSC1-C-10-SDM1

3.9.2 Items supplied

Included in the items supplied:

- PSC1 module:
 - Connectors for all signal terminals not including encoder connection

Not included in the items supplied:

- SafePLC2 software package (order designation: PSC1-A-91-SAFEPLC2) consisting of:
 - CD with configuration software
 - Licence dongle
 - Installation manual
 - Programming manual
- Programming adapter (order designation: PSC1-A-90-PROG-CABLE)

4 Safety-related features

4.1 General layout, safety-related architecture and characteristic data

The internal layout of the PSC1 series comprises two separate channels with mutual result comparison. High-quality diagnostics are undertaken in each of the two channels for fault detection.

The architecture and principle of operation of the layout corresponds to category 4 in EN ISO 13849-1.

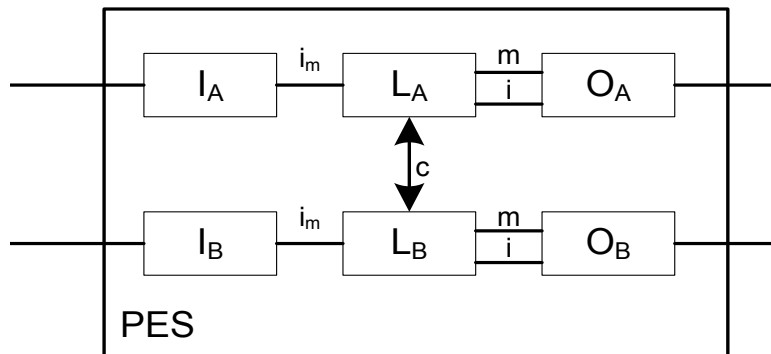

The overall architecture therefore has the following layout:

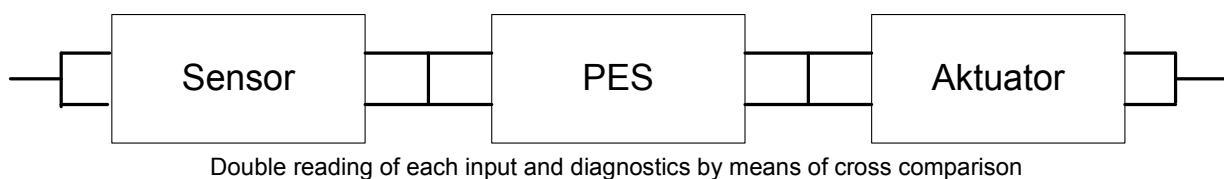

You will find the specific safety-related characteristic data for the related modules in the tech. characteristic data in section 3.

For the safety-related assessment of overall systems, the characteristic data stated in section 3 can be used for the PES sub-system (e.g. PL e and PFH value according to table for verification as per EN ISO 13849)

Only to be considered when using secure remote I/O communication (SDDC, in preparation) for data exchange with distributed I/O systems and for master – master communication (SMMC, on request):

In conjunction with the expansion modules the layout is more complex.

Along with the structures of the expansion modules, the bus communication is also to be taken into account here. The safety-related equivalent circuit / architecture is to be determined in relation to the application.

Characteristic data:

Max. achievable safety class	<ul style="list-style-type: none"> • SIL 3 as per EN61508 • Category 4 as per EN945-1 • Performance Level e as per EN ISO 13849-1
System structure	2-channel with diagnostics (1002) according to EN 61508 Architecture category 4 according to EN ISO 13849
Design of the operating mode	"High demand" as per EN 61508
Probability of a dangerous failure per hour (PFH value)	Specific values as per tables "Safety-related characteristic data"
Proof test interval (EN61508)	20 years, after that the module must be replaced

Safety instructions:

- You will find the specific safety-related characteristic data for the related modules in the tech. characteristic data in section 3.
- On the usage of several sensors with different functions (e.g. access door position indication + speed acquisition) for a safety function (e.g. safely limited speed with access door open), these are to be considered as connected in series for the safety-related assessment of the overall system. On this topic see example calculation in the appendix.
- The safety regulations and EMC directives must be followed.
- In relation to the fault exclusions assumed, reference is made to the tables in D in the annex of EN ISO 13849-2.
- For the safety-related assessment of overall systems, the characteristic data stated in section 3 can be used for the PES sub-system (e.g. PL e and PFH value according to table for verification as per EN ISO 13849)

The examples shown in the following and their characteristic architecture are definitive for the allocation to a category according to EN ISO 13849-1.

The resulting maximum possible performance levels according to EN ISO 13849 are also dependent on the following external component factors:

- Structure (single or redundant)
- Detection of common cause failures (CCF)
- Diagnostic coverage on demand (DC_{avg})
- Mean time to the dangerous failure of a channel ($MTTF_d$)

4.2 Safety-related characteristic data and circuitry for sensors connected

The PSC1 modules have completely separate signal processing paths for each safety input. In addition, measures for obtaining the highest possible DC values are implemented.

4.2.1 Digital sensors:

The digital inputs are completely redundant. The details for the categorisation, the DC and the achievable PL or SIL are listed in the following.

4.2.1.1 Characteristics of the sensors / input elements

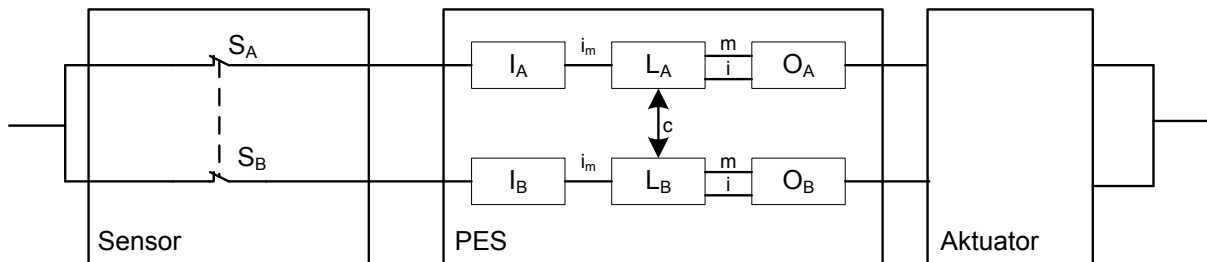

Dual-channel input element in parallel circuit (cat. 4, fault tolerance 1) with high DC due to signal processing in two channels and diagnostics using cross comparison in the PES

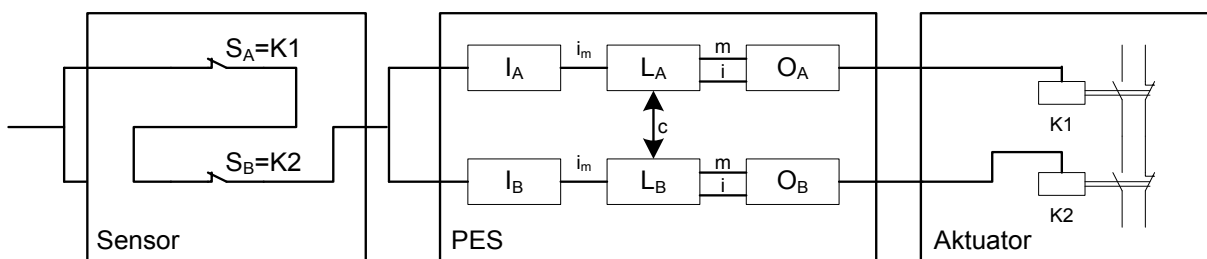

Dual-channel input element in series circuit (cat. 4, fault tolerance 1) with low to medium DC due to signal processing in two channels and diagnostics using cyclic testing

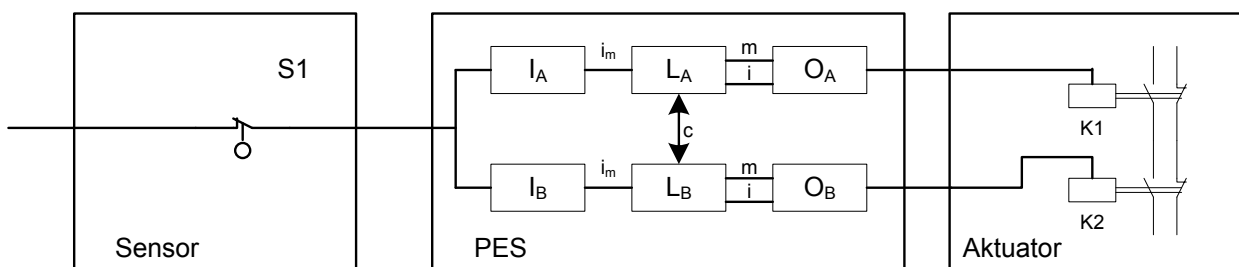

Single-channel input element and dual-channel processing with low to medium DC due to signal processing in two channels and diagnostics using cyclic testing, PL / SIL dependent on fault exclusions allowed and test rate for the input element.

4.2.1.2 DC digital sensors/inputs

The PSC1 modules provide wide-ranging diagnostic functions for the input sub-system. These are designed as continuous, or optional (cross-circuit monitoring using pulse detection, cross comparison, 2-channel or multiple-channel sensor with/without time monitoring, startup test).

Continuously active diagnostic functions:

Cross comparison:

The inputs on the PSC1 modules are in principle designed internally as dual-channel. The status of the input signals is continuously cross compared. Only with a high signal in both input sub-systems is the high status of the input detected, if the signal level varies between the two channels, the input is set to low status.

Dynamic test on the switching thresholds in the input sub-system:

The switching thresholds for the detection of the high level are tested cyclically with a high rate. If the defined threshold is dropped below, a module alarm is triggered.

Dynamic test on the ability of the input sub-system to switch:

The ability of the input sub-system to switch to the low level is tested cyclically on all inputs with the exception of I04—I07, with a high rate. If the defined threshold is dropped below, a module alarm is triggered.

Diagnostic functions that can be activated by configuring parameters:

Cross-circuit test:

The PSC1 modules have pulse signal outputs on which a unique signature is superimposed. On the usage of the cross-circuit test, the switching elements for the digital sensors / input elements are supplied with an auxiliary voltage via the pulse signal outputs on the PSC1 module. In this way the signature is superimposed on the sensors' / input elements' high signal level and checked by the PSC1 module. Short-circuits and cross-circuits to the high signal can be detected by means of the signature check. With alternating usage of the pulse signals for multiple contacts, parallel signal wires or with neighbouring terminal assignment, cross-circuits between the related input signals are detected.

Sensors / input elements with 2-pole or multiple pole contacts without time monitoring:

The sensors/input elements can be assigned to several contacts. These therefore correspond to at least 2-channel elements. A high level on the sensor/input element requires the logical connection in series of both contacts.

Example 1:

Input element with 2 normally closed contacts: High level if both contacts are closed

Example 2:

Input element with 1 normally closed contact and 1 normally open contact: High level if normally open contact actuated and normally closed contact not actuated.

Sensors / input elements with 2-pole or multiple pole contacts with time monitoring:

Same check as before however with the additional monitoring of the input signals for consistency of the defined level relationships within a time window of 3 s. If the levels differ for a period > 3 s, a module alarm is triggered.

Start-up testing:

Each time the safety module is switched on (=PSC1 module), the input element must be tested in the low signal status direction (= defined safe status), e.g. actuation of the emergency stop button or a door lock after system start.

Operative / organisational tests:

Beyond the diagnostic measures on the PSC1 modules stated above, cyclic testing can be undertaken in the application. These tests can be used in the assessment of the DC.

Note:

The operative/organisational tests can also be used for a combination of hardware inputs and functional inputs (input information transmitted via standard fieldbus). The exclusive usage of functional inputs is however excluded in this respect (combination of two or more functional inputs)

The PSC1 modules therefore provide wide-ranging diagnostic functions for the input sub-system. These are designed as continuous, or optional (cross-circuit monitoring using pulse detection).

For the safety-related assessment of the overall system, it is therefore possible in principle to use the following diagnostics for the input sensors:

Characteristics of the input element	Tests that can be configured / operative tests				DC	Definition of the measure	Comment
	Cross-circuit test	With time monitoring	Start-up testing	Cyclic test in operation			
Single-channel			O	O	>60	Cyclic test stimulus by dynamic change of input signals	An adequately high test rate must be ensured
	X				90	Cyclic test stimulus by dynamic change of input signals	Only effective if pulse allocation active
	X		O	O	90-99	Cyclic test stimulus by dynamic change of input signals	DC dependent on frequency of the start / cyclic test DC = 90 test only at intervals > 4 weeks DC = 99 test at least 1 x day/ or 100-times demand rate
Dual-channel					90	Cross monitoring of input signals with dynamic test if short circuits are not detectable (for multiple inputs/outputs)	With short-circuit fault exclusion up to DC=99 possible
			O	O	90-99	Cyclic test stimulus by dynamic change of input signals	DC dependent on frequency of the start / cyclic test
	X				99	Cross comparison of input signals with immediate and intermediate results in the logic (L) and program execution monitoring in relation to timing and logic, and detection of static failures and short-circuits (with multiple inputs/outputs)	Only effective if pulse allocation active
		X			99	Plausibility check, e.g. usage of normally open contacts and normally closed contacts = antivalent signal comparison of input elements	Only effective in conjunction with activated time monitoring function for input element

Options:

- X: Diagnostic measure activated
- O: At least 1 diagnostic measure activated

 **Safety instructions:**

- For a safety-related assessment of the sensor sub-system, the information from the manufacturer (MTTF_D, PFH figures etc.) is to be used.
- The DC values stated in the table are to be used conservatively and compliance with the boundary conditions (see "Comments" in table) ensured.
- Fault exclusions are allowed according to the applicable standards. The boundary conditions listed are to be ensured over the long-term.
- If several sensor systems are necessary for the correct function of an individual safety function, their partial values are to be combined correctly according to the method selected.

4.2.1.3 Classification of the safe digital inputs

4.2.1.3.1 Digital inputs I00 ... 13

Digital inputs	Performance Level that can be achieved	Remark
I00 ... I03 I08 ... I13	PL e	Suitable for all types of input elements, with / without pulses, achievable PL dependent on $MTTF_d$ of the input element as well as fault exclusions in the external cabling
I04 ... I07	PL e	Single-channel with pulses: <ul style="list-style-type: none"> - Predominantly high level required ($T_{High} > 100 * T_{Low}$) - At least one demand/day due to application - Fault detection on demand
	PL d	Single-channel without pulses: <ul style="list-style-type: none"> - Fault exclusion short-circuit between the signals and to VCC - Fault detection on demand
	PL e	Dual-channel: <ul style="list-style-type: none"> - At least one demand/day due to application - Fault detection on demand

4.2.1.3.2 Digital inputs I/O (IQIx)

Digital inputs	Achievable Performance Level	Remark
IQIx		Without pulse, single-channel static signal -> Signal input
	PL e	Without pulse, dual-channel static signal - At least one demand/day due to application - Fault detection only on demand
	PL d	Without pulse, dual-channel static signal - Less than one demand/day due to application
	PL e	Single-channel with pulses - Predominantly high level required ($T_{High} > 100 * T_{Low}$) - At least one demand/day due to application - Fault detection only on demand
	PL d	Single-channel with pulses - Less than one demand/day
	PL e	Dual-channel with pulse 1 and pulse 2

Note:

The achievable PL for a combination of hardware inputs and functional inputs is dependent on the operative/organisational tests selected and the independence of the two channels in the system layout. An application-related analysis is required to determine the PL.

4.2.1.4 Connection examples, digital sensors/safety switch

Attention! Identifiers for "Xxy" terminal blocks (e.g. X14) are not printed on the terminal blocks. They are used in Section 5.7 Terminal assignment to find the individual terminals more quickly, e.g. "I00".

4.2.1.4.1 Single-channel sensor, without cross-circuit testing

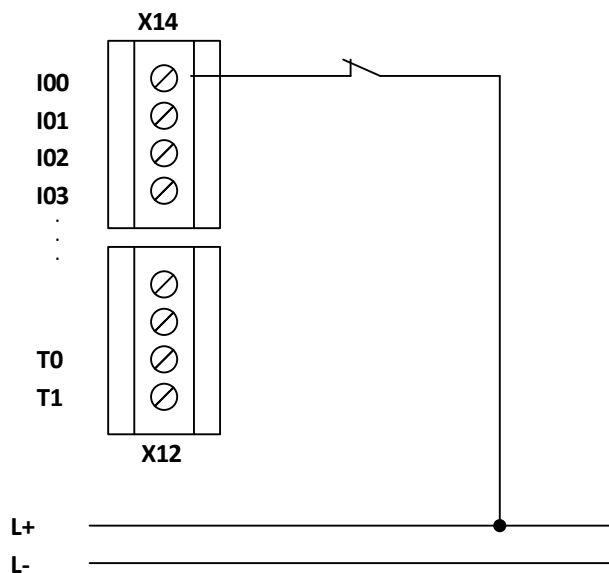

Single-channel sensor, without cross-circuit testing

The single-channel sensor is connected to the PSC1 without test pulses, and without cross-circuit testing. This design is not recommended for safety applications. Max. PL b according to EN ISO 13849-1 can be achieved.

4.2.1.4.2 Single-channel sensor with cross-circuit testing

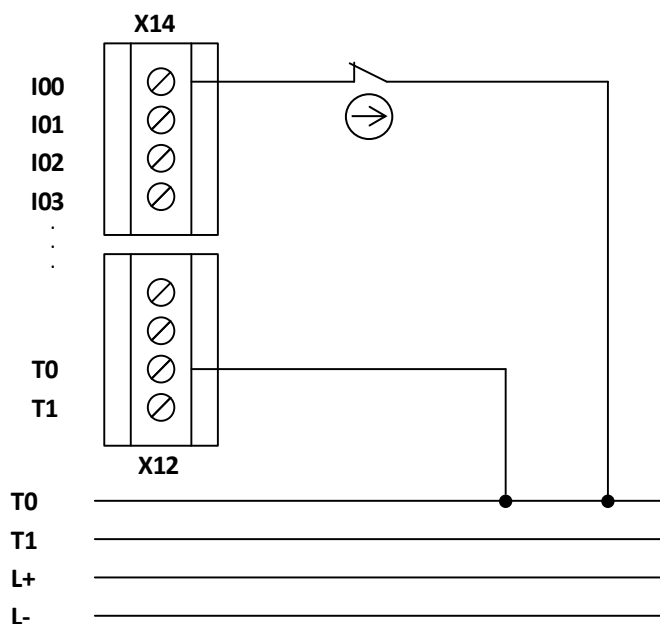

Single-channel sensor with test pulses

On the usage of a single-channel sensor with test pulses, one connection is connected to the test pulse output T0 or T1 of the PSC1. The pulse assignment must then also be carried out in SafePLC2.

The usage of a single-channel sensor with test pulses detects:

Short-circuit to the supply voltage DC 24 V

Short-circuit to DC 0 V

Cable break (interruption of power is safe state!)

Caution is required, on the other hand, if there is a cable short-circuit between the two connections for the sensor, as this will not be detected! A short-circuit between T0 and I00 is also not detected.

Due to the single-channel character of the switching element / sensor, a fault exclusion is required for its failure. This exclusion is allowed on the usage of positively opening switches with correct positive actuation.

The series connection of 2 switching elements with corresponding fault exclusion for a double fault is the same as this application (occurrence of two faults at the same time). This could represent, e.g. the safety outputs on an electronic monitoring device (light curtain, safety mat) with internal dual-channel shutdown.

On the usage of a suitable switching element and careful wiring of the sensor, PL d according to EN ISO 13849-1 can be achieved. In special cases, i.e. in conjunction with suitable switching elements and permissible fault exclusions, PL e according to EN ISO 13849-1 can be achieved.

 **Safety instructions:**

- PL d or higher according to EN ISO 13849-1 is achieved if a short-circuit between the input and related pulse output as well as a short-circuit between the sensor connections can be excluded. Here it is to be noted that in the event of a fault, the switch must be positive opening according to EN 60947-5-1. In addition, the sensor must be triggered at regular intervals and the safety function demanded. Fault exclusions can be obtained as per EN ISO 13849-2 Table D8. On the single-channel usage of the inputs, the safety level that can be achieved is limited to SIL 2 or PL d, if there is no demand for the safety function at regular intervals.
- The connection in series of 2 switch elements with fault exclusion for a double fault requires a check for suitability according to the safety level required for this element. Reference is made to the applicable stipulation in the EC Machinery directive 2006/42/EC.
- With single-channel sensors, in principle the safety-related usage of the inputs is only intended in conjunction with the pulse outputs.

4.2.1.4.3 Dual-channel sensor without time monitoring and without cross-circuit testing

Faults are detected as a minimum on demand. The DC is medium and can be changed to the high category by using cyclic tests (start tests, operative/organisational tests) depending on the test frequency.

For this purpose only normally closed contacts are to be used for safety applications.

PL d according to EN ISO 13849-1 can be achieved on the usage of sensors / switching elements with fault exclusion for the failure of the switching contacts to open. This exclusion is allowed on the usage of positively opening switches with correct positive actuation. It is also allowed to use sensors with self-monitoring output contacts.

PL e according to EN ISO 13849-1 can be achieved on the usage of diverse sensors / input elements with an adequately high $MTTF_d$ in conjunction with plausibility monitoring of the timing and an adequately high change in switching state = dynamic testing.

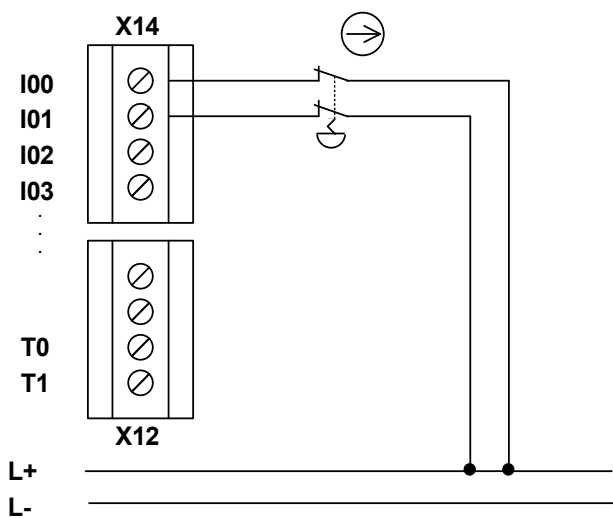

Homogeneous dual-channel sensor without test pulses, with positive opening

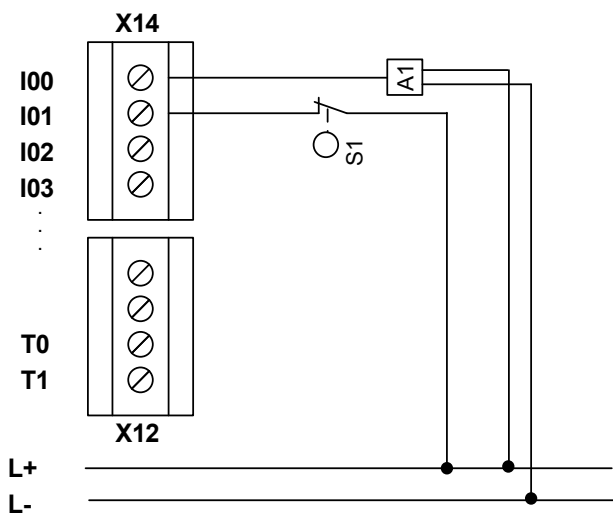

Diverse dual-channel input element, without test pulses

 **Safety instructions:**

- PL d or higher according to EN ISO 13849-1 is achieved on the usage of switching elements / sensors with positively opening contacts or positive actuation according to EN 60947-5-1.
When using sensors with non positive break contacts, the "Universal Input Module" macro (group) must be used in SafePLC2.
- The usage of devices with switching elements for which a fault exclusion for a double fault can be assumed for the safety level required is allowed. Reference is made to the applicable stipulation in the EC Machinery directive 2006/42/EC.

4.2.1.4.4 Dual-channel sensor with time monitoring and cross-circuit testing

By using two independent test pulse signals on the homogeneous sensor, all cross-circuits and connections to DC 24 V and DC 0 V can be detected.

- PL d or higher according to EN ISO 13849-1 can be achieved on:
- The usage of sensors / switching elements with positive actuation.
- The usage of 2 sensors / switching elements with independent actuation
- Ditto. However with actuation via a common actuating device in conjunction with a fault exclusion for this device.

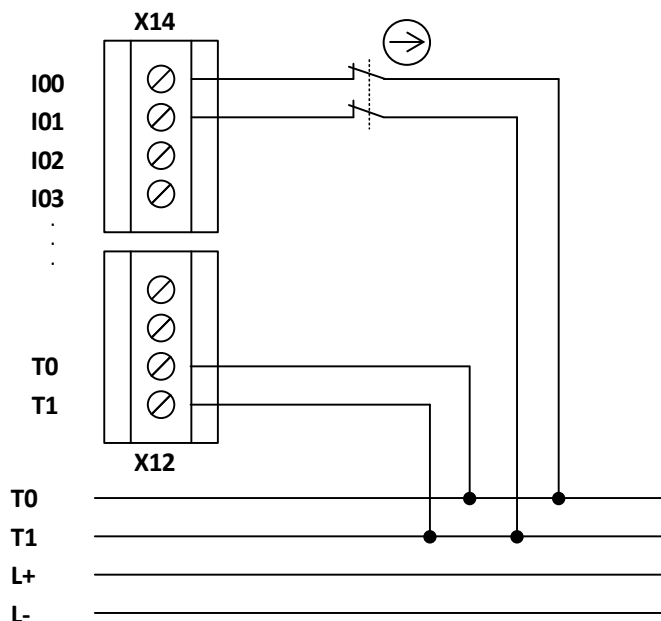

Homogeneous dual-channel sensor with test pulses

⚠ Safety instructions:

- PL d or higher according to EN ISO 13849-1 is achieved on the usage of switching elements / sensors with positive actuation.
- When using sensors with non positive break contacts or two independent sensors with independent actuation, the "Universal input module" macro (group) must be used in SafePLC2.
- On the usage of common elements in the actuating chain, a fault exclusion is required for these elements. The related restrictions and criteria according to EN ISO 13849-1 are to be met here.

4.2.1.5 Overview of achievable PL for digital safety inputs

Type of sensor / input element	Input	Tests that can be configured / operative tests				Achievable PL according to EN ISO 13849-1	Fault exclusion for input element	Condition for input element	
		Cross-circuit test	With time monitoring	Start-up testing	Cyclic test in operation				
Single-channel	I00..I13					b		Input element proven in operation	
				O	O	d	All faults on the input element Short-circuit on the input/signal wire	MTTF _d = high Connection in the switch cabinet or protected laying	
	All	I00..I04 I08..I13					e	All faults on the input element Short-circuit on the input/signal wire	Input element corresponds at least to Plr Connection in the switch cabinet or protected laying
			X				d	Stuck Short-circuit on the input/signal wire	Predominantly high level required (T _{High} > 100 * T _{Low}). Positive opening, MTTF _d = high Connection in the switch cabinet or protected laying
		X		O	O	e	All faults on the input element Short-circuit on the input/signal wire	Input element corresponds at least to Plr Connection in the switch cabinet or protected laying MTTF _d = high	
Two-channel parallel	All					d	Short-circuit between input/signal wire	Connection in the switch cabinet or protected laying MTTF _d = medium	
		X				e		MTTF _d = high	
Two-channel parallel	All		X			e	Short-circuit between input/signal wire (only with same switching elements = 2xNO or 2xNC)	Connection in the switch cabinet or protected laying MTTF _d = high	

Options:

- X: Diagnostic measure activated
- O: At least 1 diagnostic measure activated

Type of sensor / input element	Input	Tests that can be configured / operative tests				Achievable PL according to EN ISO 13849-1	Fault exclusion for input element	Condition for input element
		Cross-circuit test	With time monitoring	Start test	Cyclic test in operation			
Dual-channel serial	100..104 108..113					d	Short-circuit on the input/signal wire Stuck / positive opening	Connection in the switch cabinet or protected laying MTTF _d = medium
				O	O	e	Short-circuit on the input/signal wire	Connection in the switch cabinet or protected laying MTTF _d = high
	All			O	O	d	Short-circuit on the input/signal wire	Connection in the switch cabinet or protected laying MTTF _d = medium
		X		O	O	e		MTTF _d = high

Options:

- X: Diagnostic measure activated
- O: At least 1 diagnostic measure activated

4.2.2 Sensors for speed and/or position acquisition

4.2.2.1 General safety-related layout of sensor interface for position and/or speed

Different safety levels can be achieved depending on the encoder type and encoder combination. The safety assessment for the related sub-system is as follows:

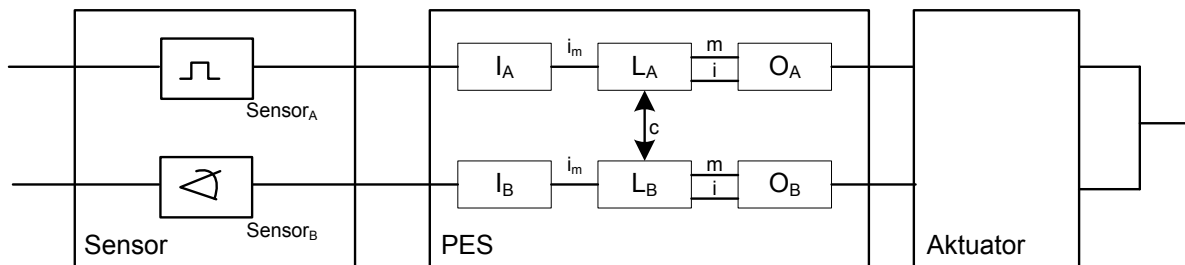

Dual-channel sensor system with separate signal processing in two channels, diagnostics by means of cross comparison in the PES

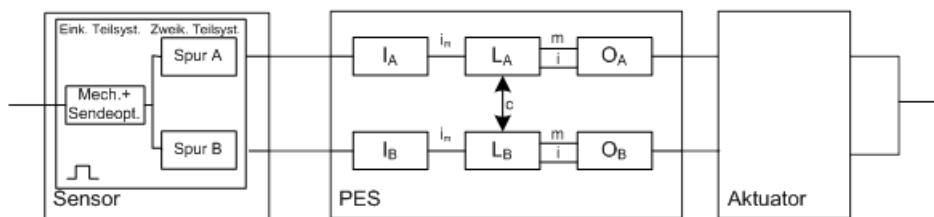

Sensor system with single and dual-channel sub-system (example incremental encoder). Diagnostics by means of separate signal processing in two channels and cross comparison in the PES as well as further specific diagnostics.

4.2.2.2 General diagnostic measures for encoder interface

For fault detection in the sensor system, a series of diagnostic measures are implemented in the PSC1 series depending on the encoder type selected and their combination. The measures are activated automatically with the selection of the encoder type.

In principle, the diagnostic measures can be classified in relation to their nature and effectiveness as per the table below:

Diagnostics for sensors for position and/or speed acquisition:

Measure	DC	Comment	Usage
Cross comparison of input signals with immediate and intermediate results in the logic (L) and program execution monitoring in relation to timing and logic, and detection of static failures and short-circuits (with multiple inputs/outputs)	99	Only for usage on: - Dual-channel sensor systems (2 separate sensors), - the dual-channel sub-system for single-channel sensors (incremental encoders) - Diagnostics for the single and dual-channel sub-system comprising specially suited sensor systems (SIN/COS encoders) Dynamic operation / no standstill monitoring	Monitoring of 2-channel sensor systems and the related sub-system in sensors for dynamic operation Not to be used for standstill monitoring!
Cross monitoring of input signals without dynamic test	80-95%	DC is dependent on the frequency of the dynamic state, i.e. standstill or movement and on the quality of the monitoring measure (80 - 90% for incremental encoders, 95% for SIN/COS encoders)	Monitoring of dual-channel sensor systems and the related sub-system comprising sensors for non-dynamic operation. To be used in particular for standstill monitoring!
Monitoring some characteristics of the sensor (response time, range of analog signals, e.g. electrical resistance, capacitance)	60	Diagnostics of specific features of sensors, can only be used for speed and position sensors according to section 4.3	Monitoring of the single-channel sub-system comprising single-channel sensor systems

4.2.2.3 Encoder types and their combinations, diagnostic characteristic data

When using a PSC1-C-10-SDM2, two cases must be considered:

- 1 axis with 2 encoders (so-called extended axis)
 - SafePLC2: Axis counter = 1
 - Combination in table: Encoder 1: Column X1/X2, encoder 2: Column X3/X4
 - Designation on device: Encoder 1: X1, encoder 2: X2

- 2 independent axes:
 - SafePLC2: Axis counter = 2
 - Axis 1:
 - Combination table: Column X1/X2, optional 2:
 - Axis 2:
 - Combination table: Column X1/X2, optional 2:
 - Designation on device:
 - Axis 1: X1 optional X23
 - Axis 2: X2 optional X23

Type <i>Encoder on interface X1/2</i>	Type <i>Encoder on Interface X3/4 (on request)</i>	Type <i>Encoder on X 23 Input (104...107)</i>	Safe speed	Safe direction	Safe position	Fault exclusion	DC		
							1-channel sub-system	2-channel sub-system dynamic	2-channel sub-system non-dynamic (standstill monitoring)
NC	NC	1 x proximity switch + 1 x proximity switch	X			Fault exclusion mech. shaft fracture, positive locking encoder shaft connection required if common element in the take-off, protected cable laying	n.a.	99%	80-90%
NC	NC	2 x proximity switch 90° + 2x proximity switch 90°	X	X	X	Fault exclusion mech. shaft fracture, positive locking encoder shaft connection, required if common element in the take-off, protected cable laying, DC values only with 2x 2x 3-wire proximity switch	n.a.	99%	99%
Incremental	NC	NC	X			Fault exclusion mech. shaft fracture, positive locking encoder shaft connection required	60%	99%	80-90%
Incremental	Incremental	NC	X	X			n.a.	99%	95%

Installation manual

Incremental	NC	1 x proximity switch	X				n.a.	99%	90-95%
Incremental	NC	2 x proximity switch 90°	X	X			n.a.	99%	90-95%
Incremental	SIN/COS	NC	X	X			n.a.	99%	99%

Installation manual

Type <i>Encoder on interface X1/2</i>	Type <i>Encoder on interface X3/4 (on request)</i>	Type <i>Encoder on X 23 (Input I04...I07)</i>	Safe speed	Safe direction	Safe position	Fault exclusion	DC		
							1-channel sub-system	2-channel sub-system dynamic	2-channel sub-system non-dynamic (standstill monitoring)
Incremental	SSI	NC	X	X	X		n.a.	99%	90-95%
SIN/COS	NC	NC	X	X		Fault exclusion mech. shaft fracture, positive locking encoder shaft connection required	90%	99%	90-95%
SIN/COS	Incremental	NC	X	X			n.a.	99%	95-99%
SIN/COS	NC	1 x proximity switch	X	X			n.a.	99%	90-95%
SIN/COS	NC	2 x proximity switch 90°	X	X			n.a.	99%	95-99%

Installation manual

Type <i>Encoder on interface X1/2</i>	Type <i>Encoder on interface X3/4 (on request)</i>	Type <i>Encoder on X 23 (Input I04...I07)</i>	Safe speed	Safe direction	Safe position	Fault exclusion	DC		
							1-channel sub-system	2-channel sub-system dynamic	2-channel sub-system non-dynamic (standstill monitoring)
SIN/COS	SSI	NC	X	X	X		n.a.	99%	95-99%
SSI	NC	2 x proximity switch 90°	X	X	X		n.a.	99%	90-95%
SSI	SIN/COS	NC	X	X	X		n.a.	99%	95-99%
SSI	SSI	NC	X	X	X		n.a.	99%	90-95%
NC	SIN/COS	NC	X	X		Fault exclusion mech. shaft fracture, positive locking encoder shaft connection required	90%	99%	90-95%

Installation manual

Type <i>Encoder on interface X1/2</i>	Type <i>Encoder on interface X3/4 (on request)</i>	Type <i>Encoder on X 23 (Input I04...I07)</i>	Safe speed	Safe direction	Safe position	Fault exclusion	DC		
							1-channel sub-system	2-channel sub-system dynamic	2-channel sub-system non-dynamic (standstill monitoring)
NC	SSI	2 x proximity switch 90°	X	X	X		n.a.	99%	90-95%

4.2.2.4 Specific diagnostic measures in relation to the encoder type used

Encoder type		Supply voltage monitoring	Differential level monitoring	SIN/COS plausibility monitoring	Input signal level monitoring	Monitoring of the permissible quadrants	Monitoring of the count signal separately for track A/B	Monitoring of the reference signal / measured signal transmission ratio	Reference signal frequency monitoring	Reference signal voltage monitoring	Measured signal form factor analysis	Plausibility test, position signal versus speed	Clk frequency monitoring
Interface X 1/2, X23	Incremental	X	X				X						
	SIN/COS	X		X									
	SSI	X	X										
	Proximity switch 2 x count input	X											
	Proximity switch 1 x count input	X											
Interface X 3/4(2)	Incremental	X	X		X		X						
	SIN_COS	X		X		X ⁽¹⁾							
	SSI	X	X									X	X

Options:

- (1) Only in the high-resolution mode
- (2) in preparation

4.2.2.5 Safety-related shutdown thresholds, encoder systems for position and speed acquisition

As a basic measure, plausibility tests between the two measurement channels A and B for speed and position on the PSC1 module are undertaken with the actual values for position and speed and tested against configured thresholds.

The **incremental shutdown threshold** describes the position deviation that can be tolerated between the two acquisition channels A and B in the measurement section unit.

The **speed shutdown threshold** describes the speed deviation that can be tolerated between the two acquisition channels A and B.

Diagnostic functions are available in the SCOPE dialogue box in the parameter configuration tool to determine the optimal parameter values for the application.

Note:

Speed and acceleration are acquired values with a minimum digital resolution. This situation limits the smallest possible speed or acceleration that can be acquired and defines the digital step size for the input values.

Speed resolution:

The speed is acquired down to a frequency of 500 Hz or 500 steps/s using the frequency measurement method, below that using a time measurement method. This situation produces the curve shown below for the acquisition error:

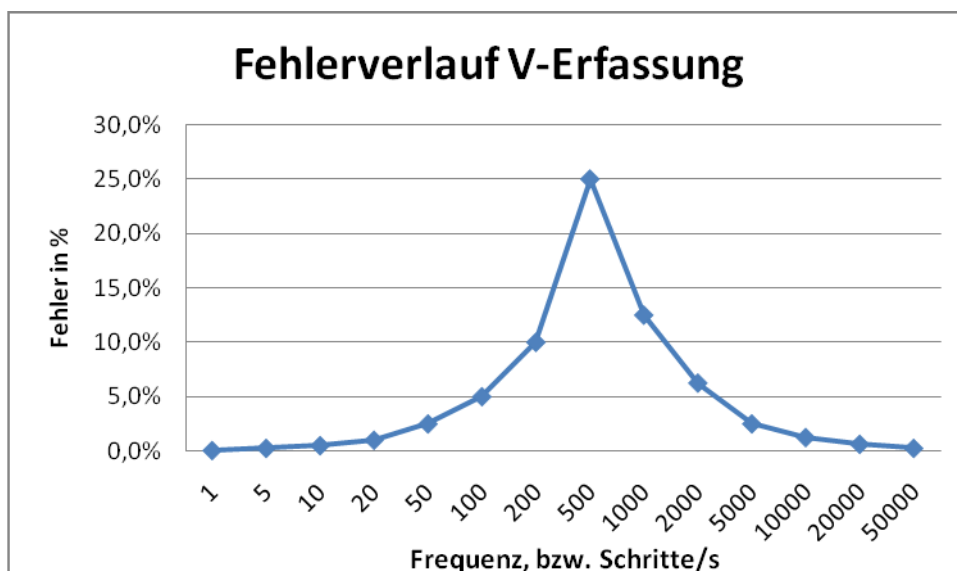

Acceleration resolution

The digital resolution of the acceleration is limited by the maximum gate time of 256 ms and the resolution of the encoders. The graph below shows the lowest acceleration that can be measured as a function of the resolution in rev/min, mm/s² and m/s².

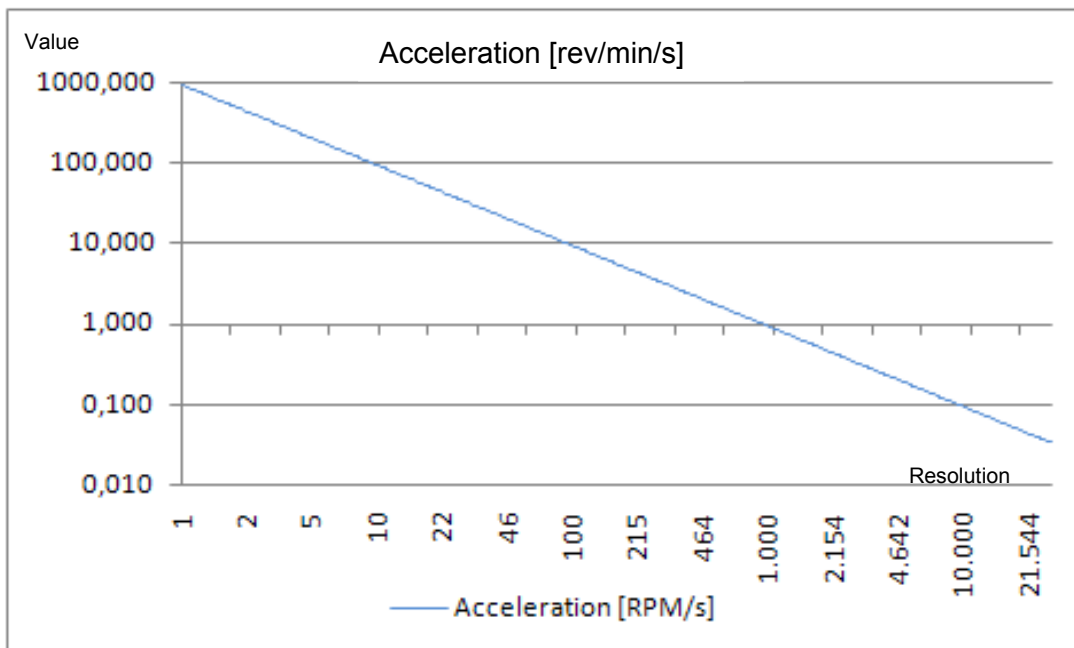

Graph of acceleration resolution, rotary (values in rev/min/s)

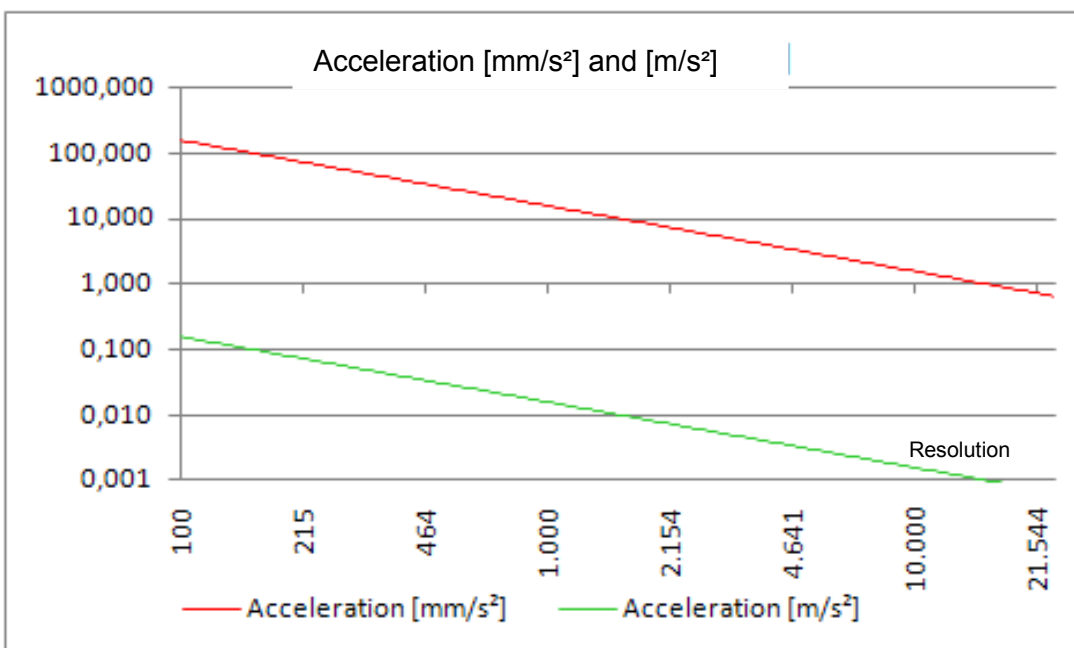

Graph of acceleration resolution, linear (values in mm/s and m/s²)

 **Safety instructions:**

- The error can be optimised by the suitable selection of the sensor resolution for the related application.
- For applications with limited resolution and/or time variance in the sampled signal, the functionality of the monitoring functions used can be improved by the usage of a mean value filter. Digital interference from the sensors is "smoothed" by the mean value filter. However, this is achieved at the cost of an increased response time for the overall system.

- The filter time can be set to between 0 and 64 in steps of 8. The dimension is "msec". To determine the response time of the overall system, the filter times must be added to the response times stated for the PSC1 system (see section 11).

 **Safety instructions:**

- For a safety-related assessment of the sensor sub-system, the information from the manufacturer (MTTF_D, PFH figures etc.) is to be used.
- If specific diagnostics are required by the manufacturer to safeguard the safety-related characteristic values stated, these are to be checked as per the above table "Specific diagnostic measures for position and speed sensors" in relation to the specific encoders. If in doubt, clarification by the manufacturer is required.
- The DC values stated in the table are to be used conservatively and compliance with the boundary conditions (see "Comments" in table) ensured.
- To determine the DC for safety functions with standstill monitoring, among other aspects it is necessary to estimate the frequency of the dynamic state. As a general figure a DC of 90% can be assumed.
- Fault exclusions are allowed according to the applicable standards. The boundary conditions listed are to be ensured over the long-term.
- If several sensor systems are necessary for the correct function of an individual safety function, their partial values are to be combined correctly according to the method selected. This statement also applies to a combination of digital and analogue sensors (e.g. safely limited speed with safety door open = door contact + encoder for speed acquisition)
- By means of the suitable selection of the resolution of the sensor system, an adequately low tolerance in relation to the shutdown thresholds for the individual safety functions is to be ensured.
- On the usage of the encoder input filter, the increase in the response time is to be taken into account during the assessment of the safety-related function.

4.2.2.6 Safety-related assessment of the encoder types and their combination

Due to the monitoring functions implemented in the PSC1 series, in applications with encoder systems there are initially no special requirements on the internal layout of the encoder electronics, i.e. as a rule standard encoders can be used.

In general, a safety-related assessment of the overall arrangement is to be undertaken. During this process the information from the manufacturer of the encoder (PFH, MTTF) as well as the DC from the tables in 4.2.2 are to be used.

On the usage of individual encoders, as a minimum a fault exclusion is required for the mechanical actuation chain as well as the single-channel part taking into account the applicable specifications from EN ISO 13849-1. The information in 4.2.2 is also to be followed.

PL d and higher according to EN ISO 13849-1 is in general achieved with a combination of two encoders with essentially different technology and separate mechanical attachment.

The usage of a compact encoder with internal dual-channel layout with different technology is just as suitable for applications up to PL e according to EN ISO 13849-1, however taking into account the specific fault exclusions required and their admissibility. As a rule encoders with proven safety-related properties should be used for this purpose; their safety level should correspond as a minimum to the level required.

Safety instructions:

- The usage of standard encoders or a combination of standard encoders is permissible. A safety-related assessment is required for the overall arrangement comprising encoders, other sensors/switching elements for triggering the safety function, the PSC1 module and the shutdown channel. To determine the safety level achieved, among other data the information from the manufacturer (PFH, MTTF) and the DC as per the specifications in 4.2.2 is to be used.
- On the usage of only one encoder, the fault exclusion shaft fracture / fault in the mechanical encoder connection is required. For this purpose suitable measures are to be taken, e.g. positive locking of the encoder connection using a slot and key or locking pin. The applicable information from the manufacturer as well as EN ISO 13849-1 in relation to the requirement and admissibility of the fault exclusion are to be followed.
- Preferably, only encoders with proven safety-related properties are to be used as individual encoders. This encoder's safety level must correspond as a minimum to the safety level required for the overall arrangement. The instructions from the manufacturer in relation to diagnostic measures, mechanical connection and measures for the supply of power are to be followed.
- SIN/COS encoders: the internal layout of the sensor system must be designed such that the output signals for both tracks are generated independently of each other and common cause failures are excluded. In addition, the mechanical layout is to be verified, e.g. fastening of the code disc to the shaft. Preferably, encoders with proven safety-related properties are to be used.

- On the usage of compact encoders with a dual-channel internal layout, e.g. SSI + incremental/SinCos, the instructions from the manufacturer in relation to the safety-related properties of diagnostic measures, mechanical connection and measures for the supply of power are to be followed. The encoder's safety level must correspond as a minimum to the safety level required for the overall arrangement. Preferably, encoders with proven safety-related properties are to be used.

In general the following faults in the external encoder system are detected by the PSC1 module:

- Short-circuits between the safety-related signal wires
- Open circuit in the safety-related signal wires
- Stuck at 0 or 1 on one or all safety-related signal wires

Further specific diagnostics for the detection of faults in the external encoder system are allocated to each encoder type. The related diagnostic measures are listed in the following for the individual encoder types together with the limiting parameters

 **Safety instructions:**

- The diagnostic measures have of course tolerances as a consequence of measurement inaccuracies. These tolerances are to be taken into account during the safety-related assessment.
- The limits for the related diagnostic measures can be configured to some extent, or are fixed. The resulting diagnostic coverages are to be assessed for the related application and included in the overall safety-related assessment.

4.3 Safety-related characteristic data and circuitry for the outputs

The PSC1 modules have safe outputs of a different type. In the circuitry the related characteristic as per the description below is to be taken into account.

4.3.1 Characteristics of the output elements

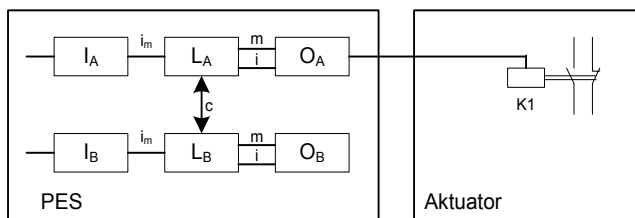

Single-channel output PSC1 and single-channel actuator without diagnostics

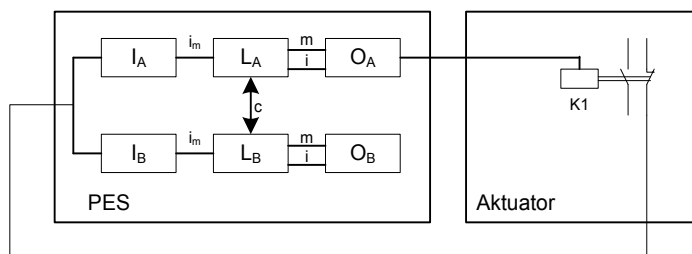

Single-channel output PSC1 and single-channel actuator with diagnostics

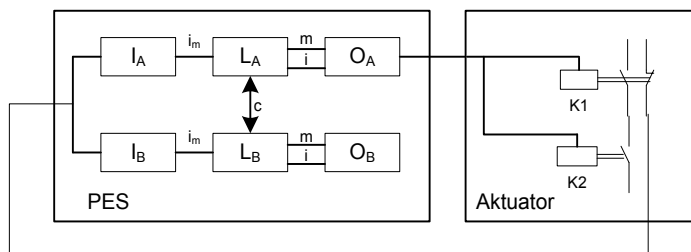

Single-channel output PSC1 (Q4/Q5, Q0/2_P, Q1/3_N) and dual-channel actuator
with at least single-channel diagnosis

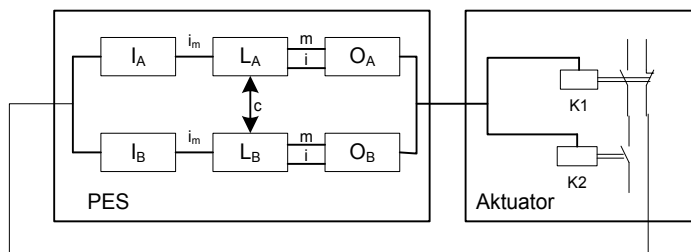

Single-channel output PSC1 with internal dual-channel processing (IQQx)
and dual-channel actuator with at least single-channel diagnostics

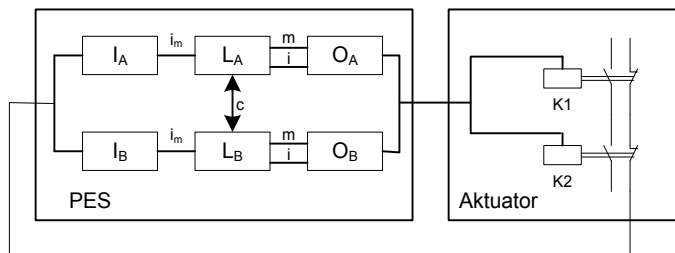

Single-channel output PSC1 with internal dual-channel processing (IQQx) and dual-channel actuator with dual-channel diagnostics

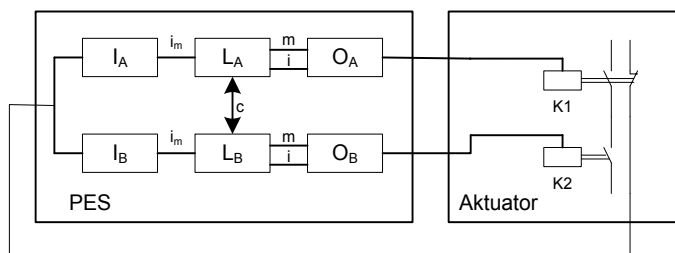

Dual-channel output PSC1 and dual-channel actuator with diagnostics

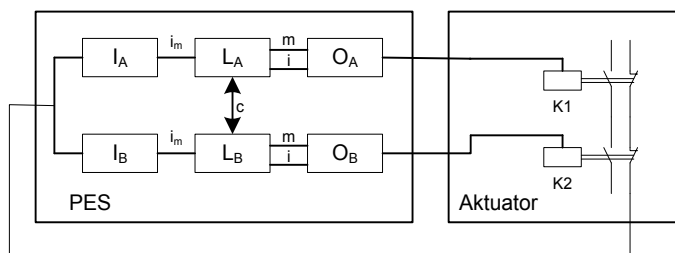

Dual-channel output PSC1 and dual-channel actuator with dual-channel diagnostics

4.3.2 Diagnostics in the shutdown circuit

The shutdown circuits have diagnostic functions with a fixed implementation and diagnostic functions that can be configured. Certain diagnostic functions also include the external part of the shutdown circuit. The various DC values are dependent on the usage of these diagnostic functions.

4.3.2.1 Diagnostic functions

Diagnostic functions with fixed implementation:

Cross-wise readback of the outputs:

All safety outputs are read back in the complementary channel. Faults in the internal shutdown circuit in the PSC1 module are therefore detected with DC = high.

Testing the shutdown capability for Q4 and Q5 (only operation of the relay), Q0, Q1, Q2, Q3:

The shutdown capability of these outputs is tested cyclically. The failure of the ability to shut down is detected unambiguously.

Diagnostic functions that can be configured:

Readback of the actuator status via auxiliary contacts, position indicators etc.:

The actual status of the actuator is acquired and compared with the required status by reading back suitable auxiliary contacts or position indicators. In this way a deviation is detected unambiguously.

Note:

The DC is dependent on single-channel or dual-channel diagnostics as well as the switching frequency.

Testing the shutdown capability for IQQx, Q0 – Q3:

The shutdown capability of these outputs is tested cyclically after the activation of the function. The failure of the ability to shut down is detected unambiguously.

4.3.2.2 Overview of DC in relation to selected diagnostic functions

Measure	DC	Comment	Usage
Monitoring of outputs by one channel without dynamic test	0-90%	<p>DC dependent on the switching frequency</p> <p>On the usage of elements for increasing the switching rating (external relays or contactors), only effective in conjunction with readback function for the switching contacts</p>	Monitoring of electromechanical, pneumatic or hydraulic actuators / outputs
Redundant shutdown path with monitoring of one of the drive elements	90%	<p>On the usage of elements for increasing the switching rating (external relays or contactors), only effective in conjunction with readback function for the switching contacts</p>	<p>Monitoring of outputs with direct function as safety circuit or monitoring of safety circuits with elements for increasing the switching rating or pneumatic / hydraulic control valves in conjunction with readback function for their switching status</p>
Cross comparison of output signals with immediate and intermediate results in the logic (L) and program execution monitoring in relation to timing and logic, and detection of static failures and short-circuits (with multiple inputs/outputs)	99%	<p>On the usage of elements for increasing the switching rating (external relays or contactors), only effective in conjunction with readback function for the switching contacts</p> <p>For applications with frequent demand for the safety shutdown, testing should be at short intervals, e.g. at the start of the shift, 1 x per week. However, a test should be undertaken cyclically at least 1 x per year.</p>	<p>Monitoring of outputs with direct function as safety circuit or monitoring of safety circuits with elements for increasing the switching rating or pneumatic / hydraulic control valves in conjunction with readback function for their switching status</p>

4.3.3 Permissible capacitive and inductive load on safe outputs

The safe outputs on the PSC1 are of an OSSD character. I.e. the outputs are shut down cyclically to test the shutdown capability and the status read back.

The test on the shutdown capability is undertaken based on the following criteria / functions:

- After the shutdown of the output, the output voltage is allowed to be max. 5.6 V
- The permissible voltage must be reached at the latest after 400 μs
- If the permissible voltage is reached, the test is considered successful, the output is re-activated without any further delay
- If the permissible voltage has still not been reached after 400 μs, an alarm is triggered and all safe outputs (second channel for safe outputs!) are deactivated

The illustration shows below the ideal (green) and typical (red) curves.

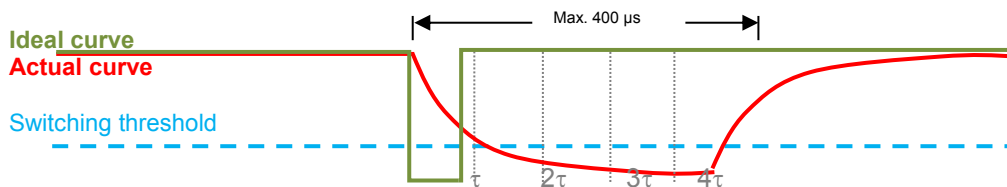

To determine the maximum permissible capacitance or inductance, the time constant τ of the actual RC or RL element on the output is to be considered.

This RC or RL element defines the actual discharge curve:

The voltage of max. 5.6 V is reliably achieved after 3τ .

Therefore:

$$3 \tau \leq 350 \mu\text{s}$$

$$\tau \leq 100 \mu\text{s}$$

With the relationship

$$\tau = RC = \frac{L}{R}$$

it is possible to determine the max. capacitive or inductive load that can be used in conjunction with the related ohmic load:

$$C_{\text{max}} = \frac{\tau}{R} = \frac{10^{-4}}{R}$$

or

$$L_{\text{max}} = \tau * R = 10^{-4} * R$$

Typical values for the capacitance C are C=20 nF and for the series inductance L = 100 mH

4.3.4 Digital outputs

The modules

- PSC1-C-10, PSC1-C-10-SDM1, PSC1-C-10-SDM2
- PSC1-E-31-..., PSC1-E-33-..., PSC1-E-37-...

each have identical outputs.

The PSC1 series provides different types of outputs that can be connected together either separately or in groups.

Output	Architecture according to EN ISO 13849-1	Remark
Combination of 2 relays Q4 – Q5	4	Complete shutdown channel corresponding to architecture category 4 according to EN ISO 13849-1
Q4,Q5, Qx.0.y-Qx.3.y	Not safe	Only functional
Q0_P and Q1_N	4	Complete shutdown channel corresponding to architecture category 4 according to EN ISO 13849-1
Q0_P	Not safe	Only functional
Q1_N	Not safe	Only functional
Q2_P and Q3_N	4	Complete shutdown channel corresponding to architecture category 4 according to EN ISO 13849-1
Q2_P	Not safe	Only functional
Q3_N	Not safe	Only functional
Q0 – Q3	4	Complete shutdown channel corresponding to architecture category 4 according to EN ISO 13849-1
Y0	Not safe	Signal output
Y1	Not safe	Signal output

The Qx_P, Qx_N and Qx outputs are subjected to a plausibility test in all operating states. In the switched in state, all outputs are tested for correct function using a cyclic test pulse. For this purpose the output is switched to the corresponding inverse value for a test duration $TT < 300 \mu s$ as a maximum, i.e. a P output is briefly switched to 0 VDC potential and an M output is briefly switched to 24 VDC potential.

The relay outputs are monitored for plausibility during each switching operation. The relay outputs must be switched cyclically and therefore tested to retain the safety function. The switching/test cycle is to be defined dependent on the application.

⚠ Safety instructions:

- For applications with frequent demand for the safety shutdown, testing should be at short intervals, e.g. at the start of the shift, 1 x per week. However, a test should be undertaken cyclically at least 1 x per year.
- The test function for the outputs is undertaken for group operation and individual operation. The signal outputs are not tested.
- The high-side (Qx_P) and low-side (Qx_N) outputs are not allowed to be used individually for safety tasks. Usage for safety tasks is only permissible in the combination high-side / low-side.
- Mixed operation of the relay contacts is not allowed!
- Mixed operation: A hazardous touch voltage potential is not allowed to be mixed with a safety extra low voltage.

Example:

INCORRECT: 230 V AC are switched via Q4.1 + Q4.2 and 24 V DC are switched via Q5.1+Q5.2.

CORRECT: 230 V AC are switched via Q4.1 + Q4.2 and Q5.1 + Q5.2 or 24 V DC are switched via Q4.1 + Q4.2 and Q5.1 + Q5.2.

The outputs can be loaded as follows:

Output	Voltage	Current
Relay Qx	24 VDC	2.0 A (DC13)
Relay Qx	230 VAC	2.0 A (AC15)
Yx	24 VDC	250 mA
Qx_P	24 VDC	2 A
Qx_N	GNDEXT	2 A
Qx	24 VDC	2 A

⚠ Safety instructions:

- For safety-related applications, only actuators with a holding power > 0.4 W or a load resistance < 100 Ω can be used.
- The derating in chapter 3.8 must be observed under all circumstances.
- A series of diagnostic measures are implemented for the output system. Attention is to be paid here in particular to the inclusion of elements for increasing the switching rating such as relays, contactors etc. in the shutdown circuit.

4.3.4.1 Example circuits, basic outputs

Attention! Identifiers for "Xxy" terminal blocks e.g. X21 are not printed on the terminal blocks. They are used in Section 5.7 Terminal assignment to find the individual terminals more quickly, e.g. "Q0_P".

4.3.4.1.1 Single-channel switching relay or semiconductor output without testing

For interfacing to multiple phase applications or if higher current is required, external contactors can be used. With single-channel connection without external testing it is to be noted that sticking of one or more external contacts will not be detected by the PSC1-C-10-x module. The example circuit in the following is only suitable for safety applications to a limited extent; a maximum of PL b according to EN ISO 13849-1 can be achieved!

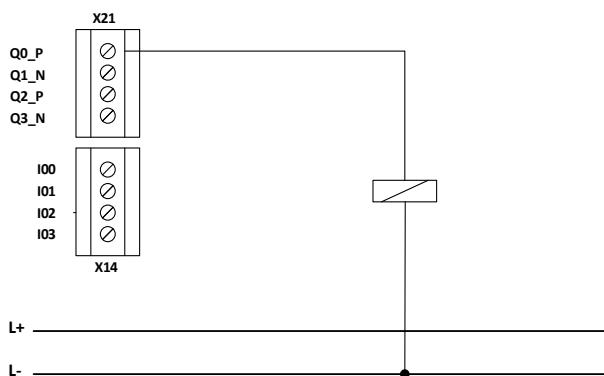

Single-channel switching P output.

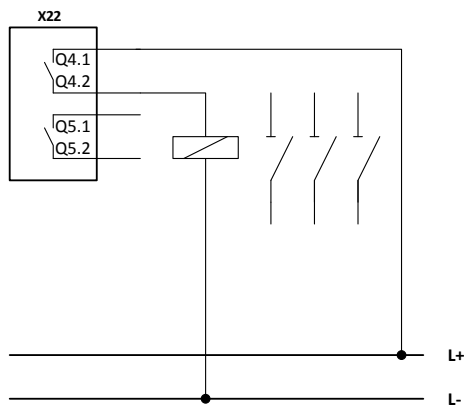

Single-channel switching relay output.



Safety instructions:

- Not recommended for safety applications! On this topic see also the information in EN ISO 13849-1 on usage and the fault exclusions necessary.

4.3.4.1.2 Single-channel switching relay or semiconductor output with external device for increasing the switching rating and testing

On the usage of an external device for increasing the switching rating, or downstream electromechanical, pneumatic or hydraulic components, a device for testing the complete chain and a signalling/warning device on the detection of a fault are required to achieve PL c or higher.

In particular, positively driven auxiliary contacts are required for electromechanical devices, or valve position signal contacts are required for hydraulic or pneumatic components. The signalling/warning device must immediately make clear the hazardous situation to the operator.

The achievable PL is heavily dependent on the test rate, a maximum of PL d according to EN ISO 13849-1 can be achieved!

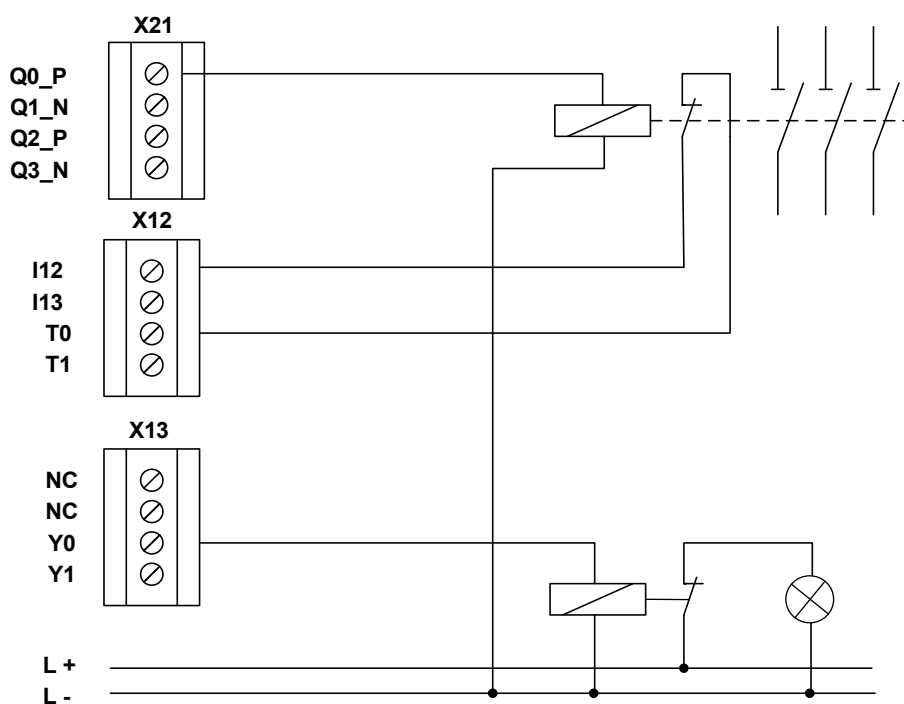

Single-channel switching relay output with testing



Safety instructions:

- Only recommended to a limited extent for safety applications! On this topic see also the information in EN ISO 13849-1 on usage and the fault exclusions necessary.
- For PL c or higher a test rate $> 100 \cdot$ demand rate is required
- For PL c and higher a signalling/warning device is required that immediately makes clear the hazardous situation to the operator

4.3.4.1.3 Single-channel switching relay or semiconductor output with dual-channel external circuit with testing

For safety applications from PL c according to EN ISO 13849-1 it is recommended or required to operate two external shutdown elements. In addition, a device for testing the complete chain and a signalling/warning device on the detection of a fault are required to achieve PL c or higher – see comments in 4.3.4.1.2.

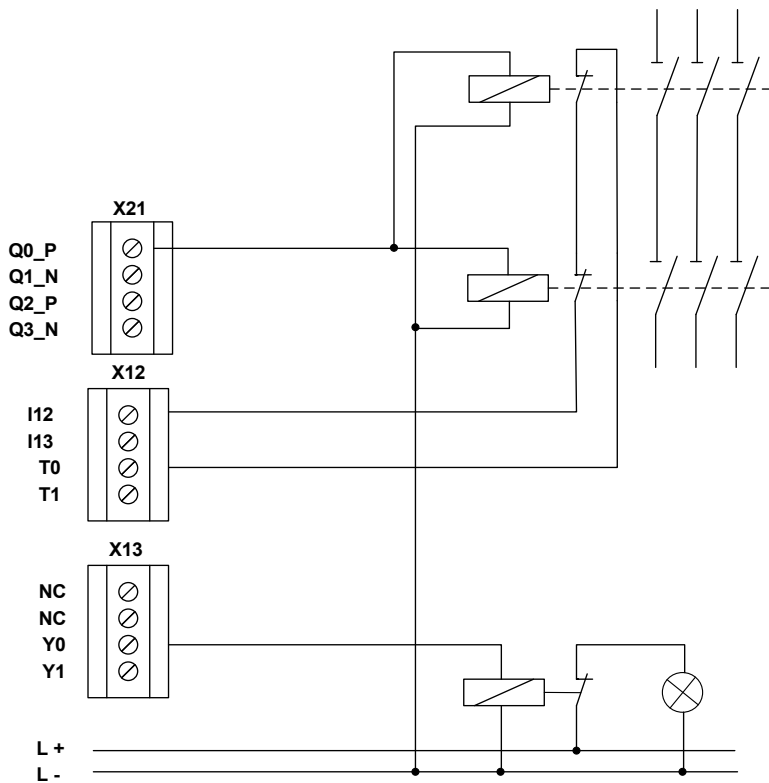

Single-channel switching output Q0_P with dual-channel external circuit and monitoring on input 12 as collective feedback

The two external monitoring contacts are connected in series, supplied with pulse signal T0 and read via input 12. Input 12 was used as the readback input, however it is also possible to use any another input.

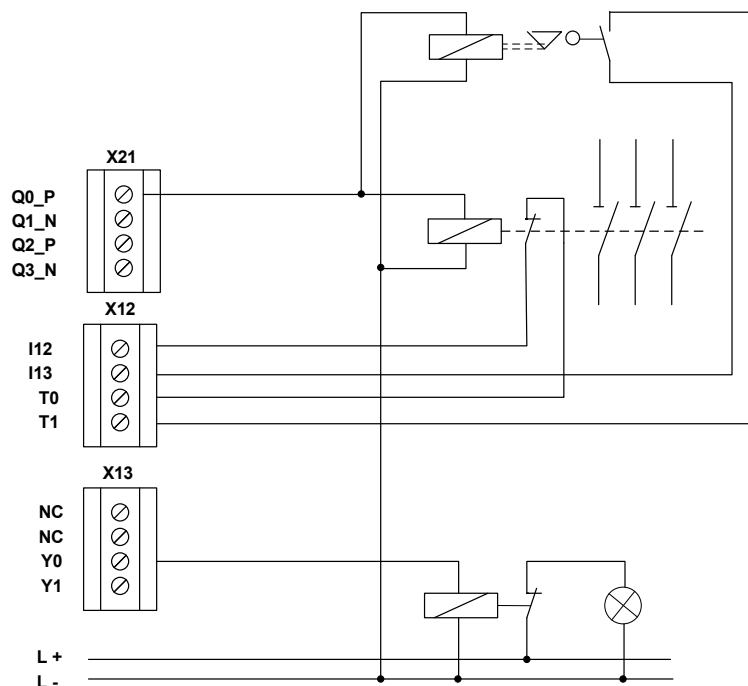

Single-channel switching output Q0_P with dual-channel external circuit as combination of electromechanical element and hydraulic/pneumatic valve monitoring on two inputs

⚠ Safety instructions:

- Only recommended to a limited extent for safety applications! On this topic see also the information in EN ISO 13849-1 on usage and the fault exclusions necessary.
- For PL c and higher a signalling/warning device is required that immediately makes clear the hazardous situation to the operator
- With increased requirements, it is to be noted that at least 1 switching process must take place every 24 hours to test the ability of the external contactor to switch.

4.3.4.1.4 Dual-channel switching relay output with external monitoring – collective feedback

For safety applications from PL d according to EN ISO 13849-1, two relays are used in the PSC1-C-10-x module and two external contactors.

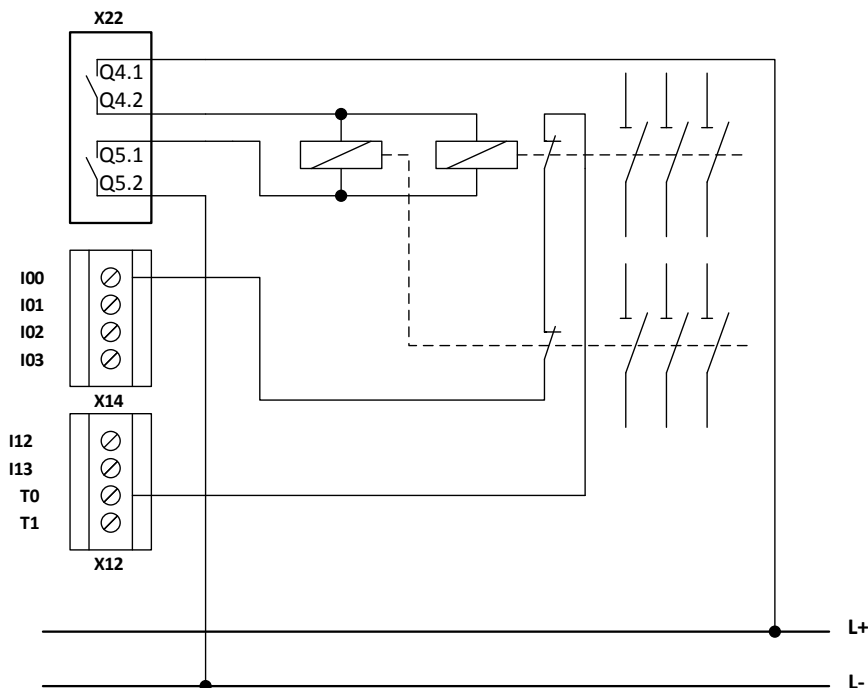

Dual-channel switching relay output with external monitoring – collective feedback

The two external monitoring contacts are connected in series, supplied with pulse signal T0 and read by I00 (configured as EMU input). With increased requirements, it is to be noted that at least 1 switching process must take place at least every 24 hours.

Safety instructions:

- An adequately high test rate is required to achieve PL e according to EN ISO 13849-1.
- For applications with frequent demand for the safety shutdown, testing should be at short intervals, e.g. at the start of the shift, 1x per week. However, a test should be undertaken cyclically at least 1 x per year.

4.3.4.1.5 Dual-channel output with relay output and semiconductor output – external control circuit with monitoring

For safety applications from PL d and higher according to EN ISO 13849-1. The external circuit is operated using two channels via one relay output and one semiconductor output. Each of the two external shutdown paths is monitored. An adequately high test rate as well as $MTTF_d = \text{high}$ for the external circuit are required for PL e according to EN ISO 13849-1.

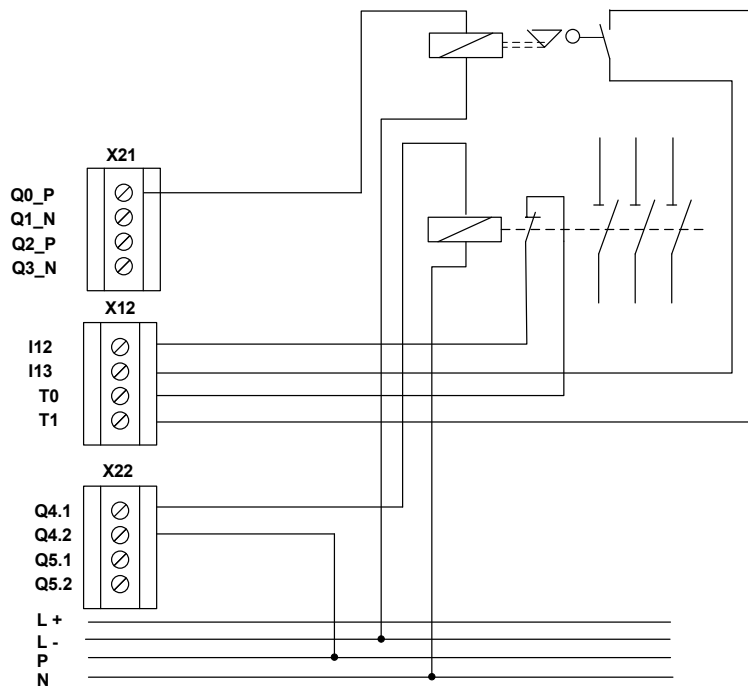

Dual-channel output with relay output and semiconductor output – external control circuit with monitoring

4.3.4.1.6 Dual-channel output with relay output - external control circuit in PL e

For safety applications from PL d and higher according to EN ISO 13849-1. The external circuit is operated using two channels via the relay outputs. An adequately high test rate as well as PL e for the external circuit are required for PL e according to EN ISO 13849-1.

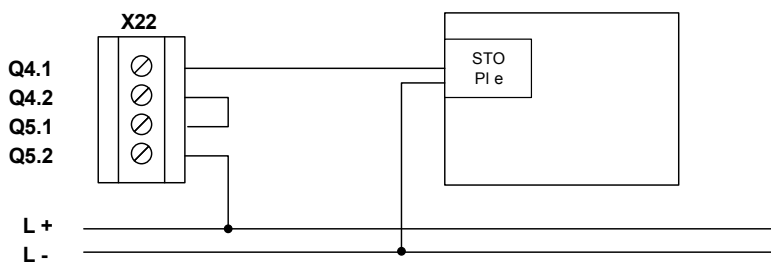

Dual-channel output with relay output - external control circuit in PL e

4.3.4.1.7 Dual-channel output with semiconductor output and external control circuit in PL e

For safety applications from PL d and higher according to EN ISO 13849-1. The external circuit is operated using two channels via semiconductor outputs. PL e is required for the external circuit for PL e according to EN ISO 13849-1.

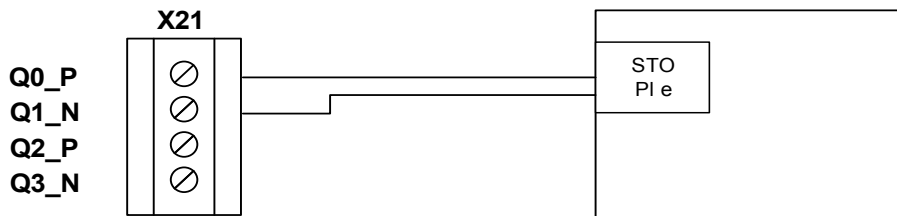

Dual-channel output with semiconductor output and external control circuit in PL e

4.3.4.1.8 Connecting an signal output

Both of the semiconductor outputs implemented in the PSC1-C-10-x module can be used for functional applications. The outputs are not pulsed.

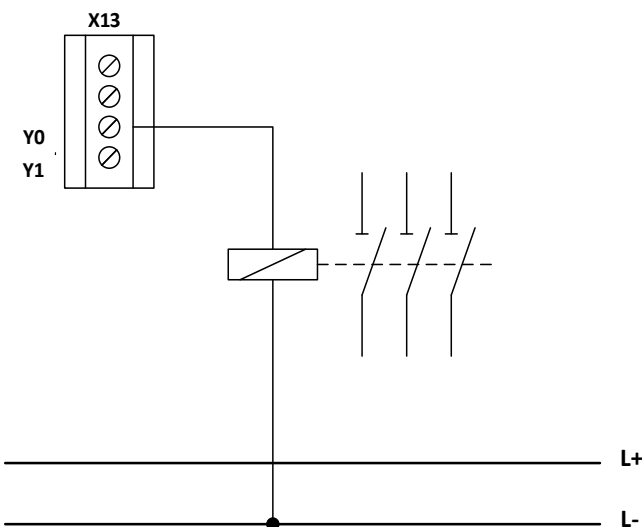

Connecting an signal output

Applications with auxiliary outputs are not allowed for safety applications!

4.3.5 Digital outputs I/O (IQQx)

The expansion modules PSC1-E-31-... and PSC1-E-33-... have configurable safe digital I/O (see section 3.6 Module overview). Configured as an output, this connection acts as a safe digital pp switching output (IQQx).

4.3.5.1 Classification of the I/O (IQQx) on usage as an output

Classification	Achievable PL according to EN ISO13849-1	Remark
Static single-channel ²⁾	PL c	- Fault detection and fault reaction as per sec. 2
Static dual-channel ²⁾	PL d	Same group ¹⁾ : - Operation delayed at PLC level - Fault assumption short-circuit on both outputs Different group ¹⁾ : - No further requirement necessary
	PL e	Different group ¹⁾
Dynamic single-channel ²⁾	PL e	No further requirement necessary
Dynamic dual-channel ²⁾		

Note:

- 1) Group 1: IQQ00 ... IQQ05
 Group 2: IQQ06 ... IQQ09
- 2) Static: No pulse test on the output
 Dynamic: Pulse test on the output with $t_{Test} \leq 500 \mu s$

4.3.5.2 Example circuits for safe digital outputs I/O (IQQx)

Attention! Identifiers for "Xxy" terminal blocks e.g. X12 are not printed on the terminal blocks. They are used in Section 5.7 Terminal assignment to find the individual terminals more quickly, e.g. "IQQ00".

4.3.5.2.1 Single-channel circuit without testing

On the usage of a dual-channel output (IQQx) in conjunction with an external single-channel circuit without external testing, it is to be noted that sticking of one or more external contacts will not be detected by the PSC1-C-10-x module. The example circuit in the following is only suitable for safety applications to a limited extent; a maximum of PL b according to EN ISO 13849-1 can be achieved!

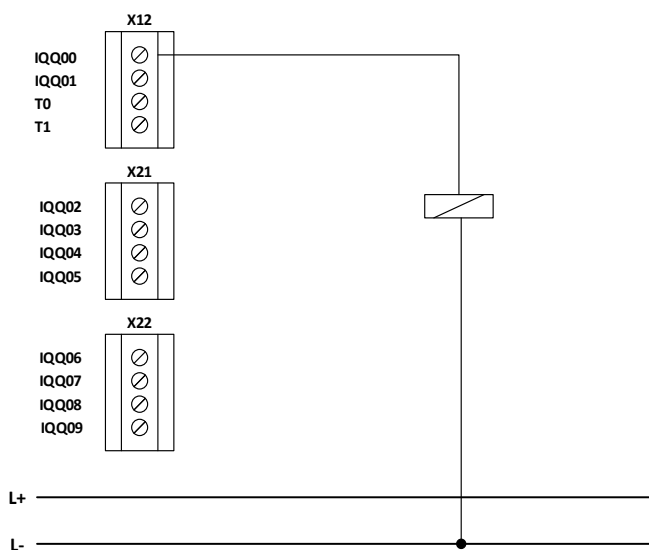

Dual-channel output with single-channel circuit without testing

Safety instructions:

- Not recommended for safety applications! On this topic see also the information in EN ISO 13849-1 on usage and the fault exclusions necessary.

4.3.5.2.2 Single-channel circuit with testing

On the usage of a dual-channel output (IQQx) in conjunction with an external single-channel circuit with testing. In particular, positively driven auxiliary contacts are required for electromechanical devices, or valve position signal contacts are required for this purpose for hydraulic or pneumatic components. A signalling/warning device for the indication of the failure is required. The signalling/warning device must immediately make clear the hazardous situation to the operator.

The achievable PL is heavily dependent on the test rate, a maximum of PL d according to EN ISO 13849-1 can be achieved!

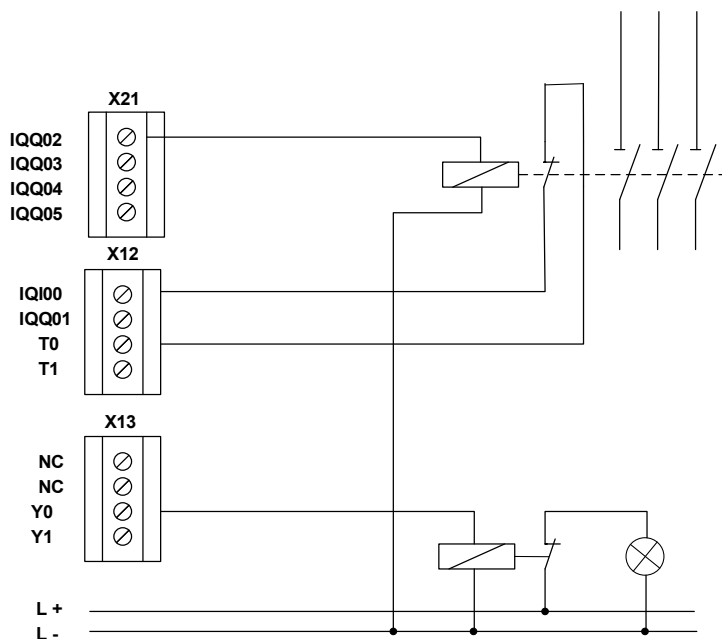

Dual-channel output with single-channel circuit with testing

Safety instructions:

- Only recommended to a limited extent for safety applications! On this topic see also the information in EN ISO 13849-1 on usage and the fault exclusions necessary.
- For PL cn/Kat 2 or higher a test rate $> 100 \cdot \text{demand rate}$ is required
Alternatively, testing of the safety function can now also be carried out immediately upon request, if the total time required to detect the failure and to transfer the machine to a safe state (usually the machine is stopped) is shorter than the time required to reach the hazard.
- For PL c and higher a signalling/warning device is required that immediately makes clear the hazardous situation to the operator

4.3.5.2.3 Circuit with safe shutdown circuit

For safety applications from PL c and higher according to EN ISO 13849-1. The external circuit is operated directly using a dual-channel output. The achievable PL according to EN ISO 13849-1 is dependent on the usage of dynamic testing (see 4.3.2.1 DC) as well as the PL for the downstream device.

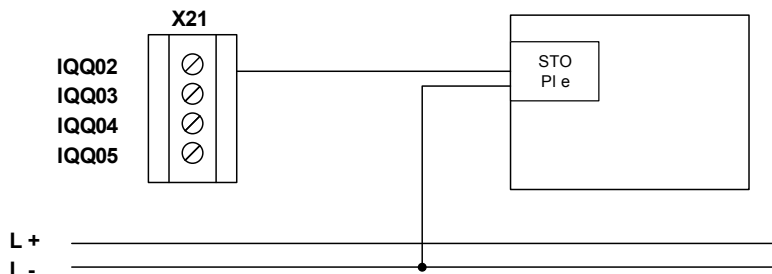

Dual-channel output in conjunction with device with tested shutdown

4.3.5.2.4 Circuit in conjunction with dual-channel shutdown circuit

Suitable for PL d or higher according to EN ISO 13849-1. Usage of one output IQQx in conjunction with a dual-channel external circuit with testing. In particular, positively driven auxiliary contacts are required for electromechanical devices, or valve position signal contacts are required for this purpose for hydraulic or pneumatic components. The achievable PL is dependent on the dynamic testing as well as the $MTTF_D$ for the external circuit. A maximum of PL e according to EN ISO 13849-1 can be achieved!

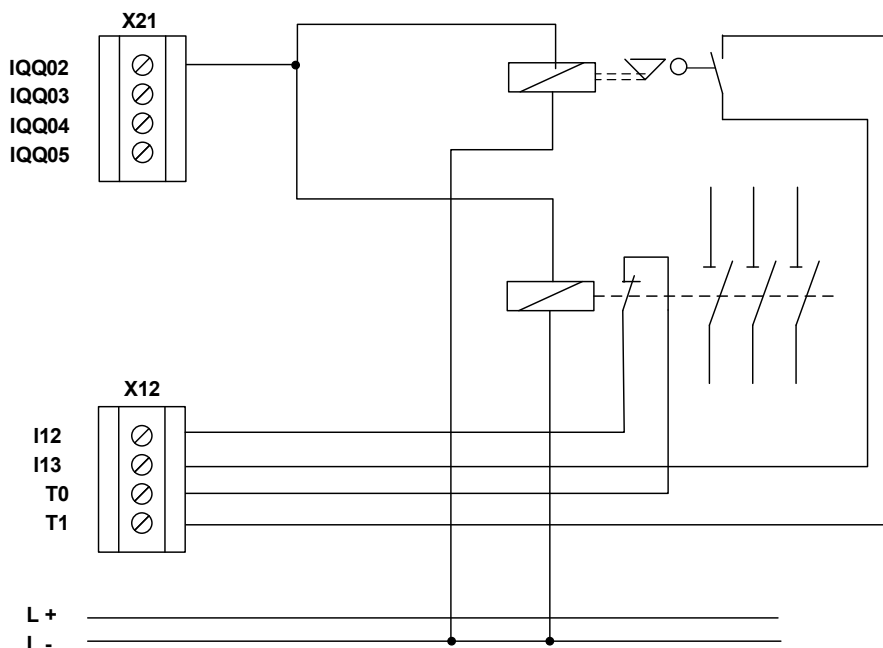

Dual-channel output in conjunction with dual-channel shutdown circuit with testing

 **Safety instructions:**

- For the safety-related assessment of the output sub-system, on the usage of external elements in the shutdown circuit, e.g. for increasing the switching rating, the information from the manufacturer (MTTF_D, PFH figures, B10d value etc.) is to be used.
- The DC values stated in the table are to be used conservatively and compliance with the boundary conditions (see "Comments" in table) ensured.
- Fault exclusions are allowed according to the applicable standards. The boundary conditions listed are to be ensured over the long-term.
- On the usage of elements for increasing the switching rating in safety circuits, the function of these elements is to be monitored using suitable readback contacts etc. (see example circuits). Suitable readback contacts are contacts that are forced to switch with the contacts in the shutdown circuit.
- The ability of the external device for increasing the switching rating to switch is to be checked cyclically. The interval between 2 tests is to be defined to suit the requirement based on the application and safeguarded by means of suitable measures. Suitable measures can be of an organisational (switching off and on at the start of the shift etc.) or technical (automatic, cyclic switching) nature.

4.3.5.2.5 Redundant dual-channel output

Suitable for PL d or higher according to EN ISO 13849-1. Usage of two outputs IQQx in conjunction with a dual-channel external circuit.

4.3.5.2.5.1 Dual-channel circuit in same group

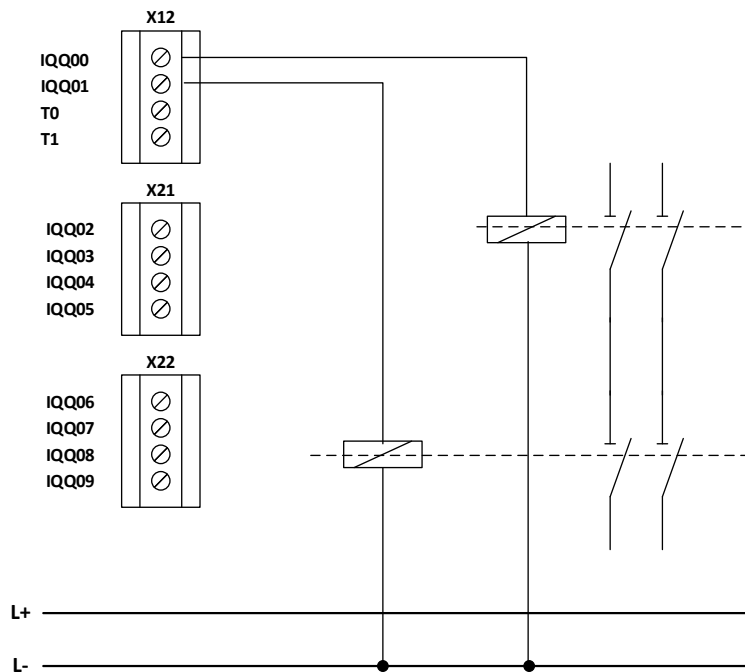

Redundant dual-channel outputs in same group in conjunction with dual-channel shutdown circuit

4.3.5.2.5.2 Dual-channel circuit in different groups

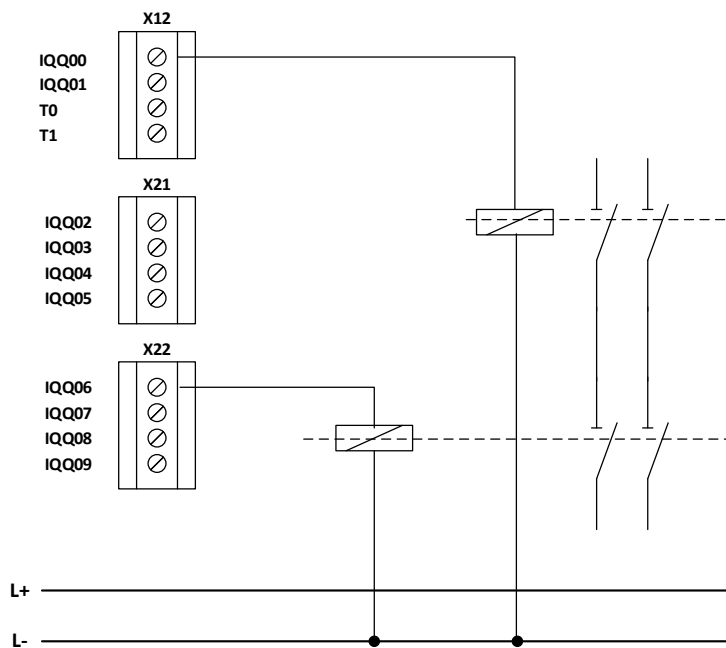

Redundant dual-channel outputs in different groups in conjunction with dual-channel shutdown circuit

⚠ Safety instructions:

- For the safety-related assessment of the output sub-system, on the usage of external elements in the shutdown circuit, e.g. for increasing the switching rating, the information from the manufacturer (MTTF_D, PFH figures, B10d value etc.) is to be used.
- The DC values stated in the table are to be used conservatively and compliance with the boundary conditions (see "Comments" in table) ensured.
- Fault exclusions are allowed according to the applicable standards. The boundary conditions listed are to be ensured over the long-term.
- On the usage of elements for increasing the switching rating in safety circuits, the function of these elements is to be monitored using suitable readback contacts etc. (see example circuits). Suitable readback contacts are contacts that are forced to switch with the contacts in the shutdown circuit.
- The ability of the external device for increasing the switching rating to switch is to be checked cyclically. The interval between two tests is to be defined to suit the requirement based on the application and safeguarded by means of suitable measures. Suitable measures can be of an organisational (switching off and on at the start of the shift etc.) or technical (automatic, cyclic switching) nature.

4.3.5.3 Overview of achievable PL for digital safety outputs

Output PSC1	Actuator / external shutdown circuit	Category according to EN ISO 13849-1	DC		MTTF _d actuator	Achievable PL according to EN ISO 13849-1	Boundary condition	Fault exclusion
Single-channel without dynamic output test Qx Q0_P, Q1_N, Q2_P, Q3_N IQQx	Single-channel Contactor, valve, brake etc. without direct feedback for diagnostics	Cat. B	0 %		Medium	B	Contactors and downstream actuators suitably designed for safety application	
	Single-channel Contactor, valve, brake etc. with monitored, positively driven auxiliary contact	Cat. 2	60-90 %	Dependent on switching frequency	Medium	B	Signal output required for warning if malfunction detected	Contactors and downstream actuators suitably designed for safety application
					High	C	As before	
						D	As before DC = 90% due to adequately high test rate in relation to the application	
Single-channel without dynamic output test Qx or Single-channel Q0_P, Q1_N, Q2_P, Q3_N	Dual-channel Contactor, valve, brake etc. with direct feedback for diagnostics in at least one channel or Actuator operated with single channel with safety function cat. 3 (e.g. STO)	Cat. 2	90 %	Monitoring only in one external shutdown circuit	Medium	c	Signal output required for warning if malfunction detected	Short-circuit on external operation
					High	d	Contactors and downstream actuators suitably designed for safety application	
Single-channel without dynamic output test IQQ00 ..IQQ09	Dual-channel Contactor, valve, brake etc. with direct feedback for diagnostics in at least one channel or Actuator operated with single channel with safety function cat. 3 (e.g. STO)	Cat. 3	90 %	Monitoring only in one external shutdown circuit	Medium or high	d	Contactors and downstream actuators suitably designed for safety application	Short-circuit on external operation
Single-channel with dynamic output test IQQ00 ..IQQ09	Dual-channel Contactor, valve, brake etc. with direct feedback for diagnostics in both channels or Actuator with safety function cat. 4 (e.g. STO)	Cat. 4	99 %	Monitoring in both external shutdown circuits	High	e	Contactors and downstream actuators suitably designed for safety application Monitoring electromechanical components by means of positively driven switches, position monitoring on switching valves etc.	

Output PSC1	Actuator / external shutdown circuit	Category according to EN ISO 13849-1	DC		MTTF _d actuator	Achievable PL according to EN ISO 13849-1	Boundary condition	Fault exclusion
Dual-channel without dynamic output test Q0/Q1, Q2/Q3 2 x IQQ00 ..IQQ09	Dual-channel Contactor, valve, brake etc. with direct feedback for diagnostics in at least one channel or Actuator with safety function cat. 4 (e.g. STO)	Cat. 3	90%	Monitoring in both external shutdown circuits	Medium or high	d	<p>Contactor and downstream actuators suitably designed for safety application</p> <p>Monitoring electromechanical components by means of positively driven switches, position monitoring on switching valves etc.</p> <p>Outputs IQQ0...19 1 x from different groups (groups of 6/4 contiguous IQQ ports, e.g. IQQ0...5, IQQ6...9)</p> <p>or</p> <p>Operation delayed at PLC level</p>	Short-circuit on external operation
Dual-channel Q0/Q1, Q2/Q3 or Dual-channel with dynamic output test Q0_P and Q1_N, Q2_P and Q3_N 2 x IQQ00 ..IQQ09	Dual-channel Contactor, valve, brake etc. with direct feedback for diagnostics in both channels or Actuator with safety function cat. 4 (e.g. STO)	Cat. 4	99%	Monitoring in both external shutdown circuits	High	e	<p>Contactor and downstream actuators suitably designed for safety application</p> <p>Monitoring electromechanical components by means of positively driven switches, position monitoring on switching valves etc.</p> <p>For applications with frequent demand for the safety shutdown, testing should be at short intervals, e.g. at the start of the shift, 1 x per week. However, a test should be undertaken cyclically at least 1 x per year.</p>	Short-circuit on external operation in both channels

5 Connection and installation

5.1 General installation instructions

It is imperative you follow the safety instructions during installation!

Degree of protection IP20

Lay all signal wires for connection to the digital inputs and contact monitoring separately. In all circumstances separate voltages of 230 VAC from low-voltage wires, if these voltages are used in relation to the application.

The length of the cables for the digital inputs and outputs should in general not exceed **30 m**. If the cable length exceeds a value of 30 m, suitable measures are to be taken to exclude inadmissible overvoltage faults. Suitable measures are, for instance, lightning protection for wires outdoors, overvoltage protection for the installation indoors, protected cable laying.

Measures for electromagnetic compatibility (EMC)

The PSC1 module is intended to be used with drives and meets the EMC requirements stated above.

In addition, it is a prerequisite that the electromagnetic compatibility of the overall system is safeguarded using customary measures.

Safety instructions:

- It is to be ensured that the power supply wires for the PSC1 and "switching wires" for the power converter are laid separately.
- Signal wires and power wires for the power converter are to be laid in separate cable ducts. The distance between the cable ducts should be at least 10 mm.
- Only screened wires are to be used to connect the position and speed sensors. The cables for the transmission of the signals must be suitable for the RS-485 standard (twisted pairs).
- The screen is to be connected correctly to the 9-pin SUB-D connectors for the position and speed acquisition sensors. Only metal or metallised connectors are allowed.
- The screen at the sensor end must be laid according to customary methods.
- Attention is to be paid to the correct installation in relation to EMC of the power converter technology in the area of the PSC1 module. Particular attention should be paid to cable routing and the connection of the screen for the motor cable and the connection of brake resistor. Here it is imperative the installation guidelines from the manufacturer of the power converter are followed.

- All contactors in the area of the converter must be equipped with an appropriate suppressor circuit.
- All contactors or comparable switching amplifiers must be equipped with appropriate protective circuitry (e.g. free-wheeling diodes).
- Suitable measures for protection against overvoltages are to be taken.

5.2 Installation and mounting PSC1 module

The module is only installed in switch cabinets that meet degree of protection IP54 as a minimum.

The modules must be fastened vertically on a DIN rail

The ventilation slots must be kept adequately clear to ensure the circulation of air inside the module.

5.3 Mounting backplane bus

The backplane bus comprises a 5-pin connector with spring contacts. As standard, all 5 contacts are used on the connectors.

Remark:

Expansion modules do not have a dedicated power supply unit and rely on the backplane bus for a DC supply. Basic modules (PSC1-C-10(-SDMx)(-FBx)) have a more powerful power supply unit and always provide a supply on the backplane bus.

There is currently only one type of backplane bus connector:

- **PSC1-A-80-CON-TBUS-POWER:**
Standard version (all contacts are available)

(Colour may differ from backplane bus connectors shown in 5.3.1)

Usage of the backplane bus connector PSC1-A-80-CON-TBUS-POWER:

The backplane connector **PSC1-A-80-CON-TBUS-POWER** can only be installed in conjunction with expansion modules without a dedicated supply of power. It is not possible to connect several standalone modules.

5.3.1 Arrangement examples

5.3.1.1 PSC1-C-10-SDM1 + PSC1-E-31-.... + PSC1-E-33-....

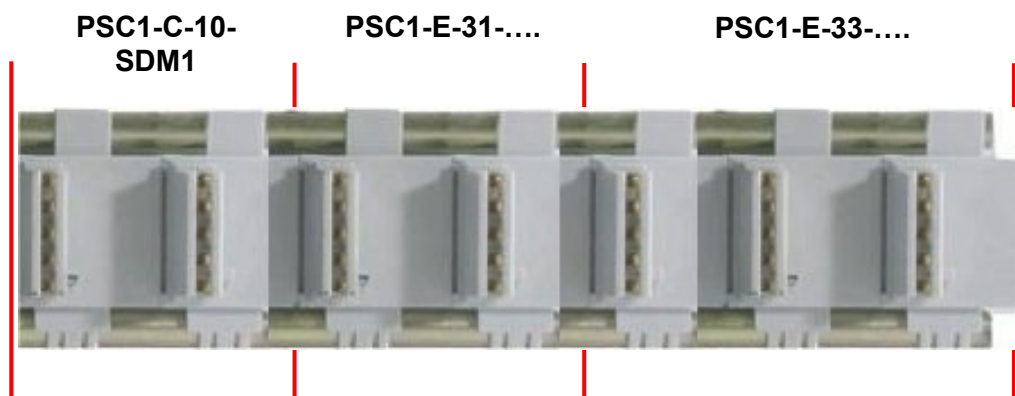

5.3.1.2 PSC1-C-10-SDM2 + PSC1-E-33-....

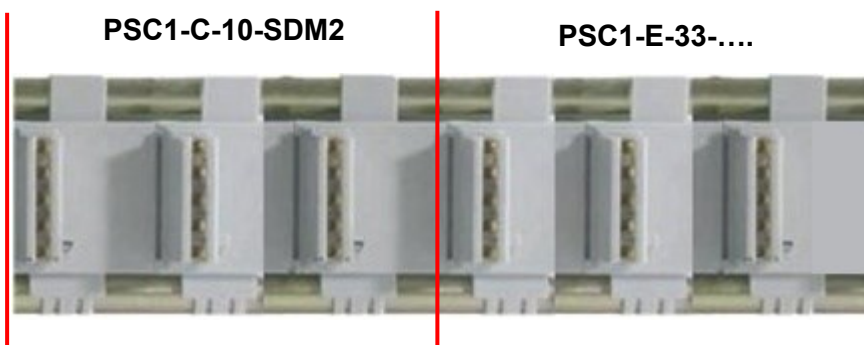

5.4 Mounting the modules

The modules are mounted on standard C rails using a snap-action catch

5.4.1 Mounting on C rail

The devices are fitted to the rail from above at an angle and snapped downward. They are removed using a screwdriver that is inserted in the slot on the catch protruding from the bottom of the device and then moved upward.

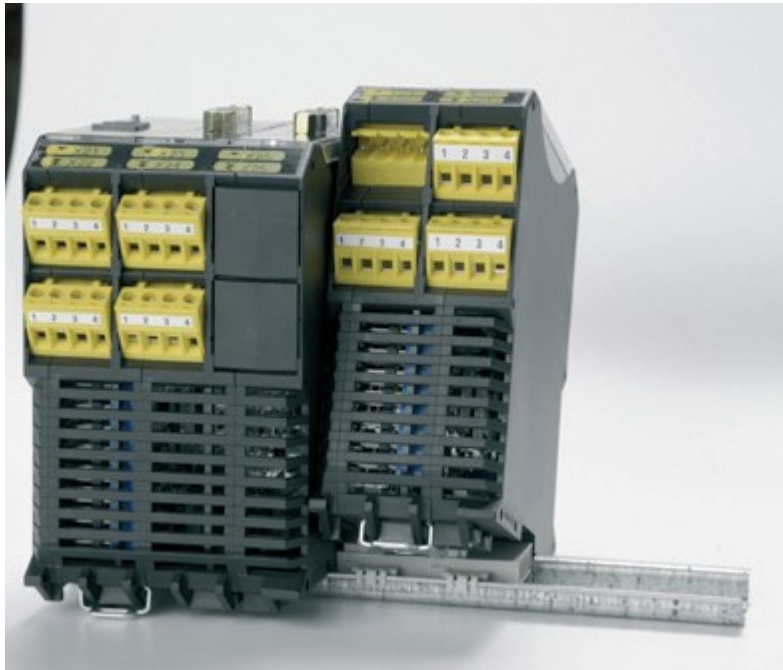

5.4.2 Mounting on backplane bus

After mounting the backplane bus, the devices can be mounted. For this purpose the module is fitted to the connector at an angle from above and snapped to the C rail



Fit module at an angle from above



Snap down onto the C rail

The backplane connection can be retrofitted. In this way the system configuration can be expanded with additional modules.



Snap backplane bus element to C rail and insert in the mating piece by pushing to the side

5.5 Installation and configuration of master ↔ master (SMMC) and master ↔ slave (SDDC)

- ⇒ SMMC on request
- ⇒ SDDC in preparation

The SMMC communication makes it possible to exchange safely 2 bytes of data between several masters.

Communication takes place without the master for the co-ordination of the data. As such there is always an exchange of data between available bus users.

Due to this principle of operation, an incomplete or disconnected network can operate in sections without changing the configuration.

To be able to co-ordinate several masters with different cycle times, an SMMC cycle time is configured in the parameters; this cycle time must be maintained by all bus users.

This cycle time is the smallest common multiple of the cycle time of the individual bus users.

5.5.1 Schematic diagram of the network topology

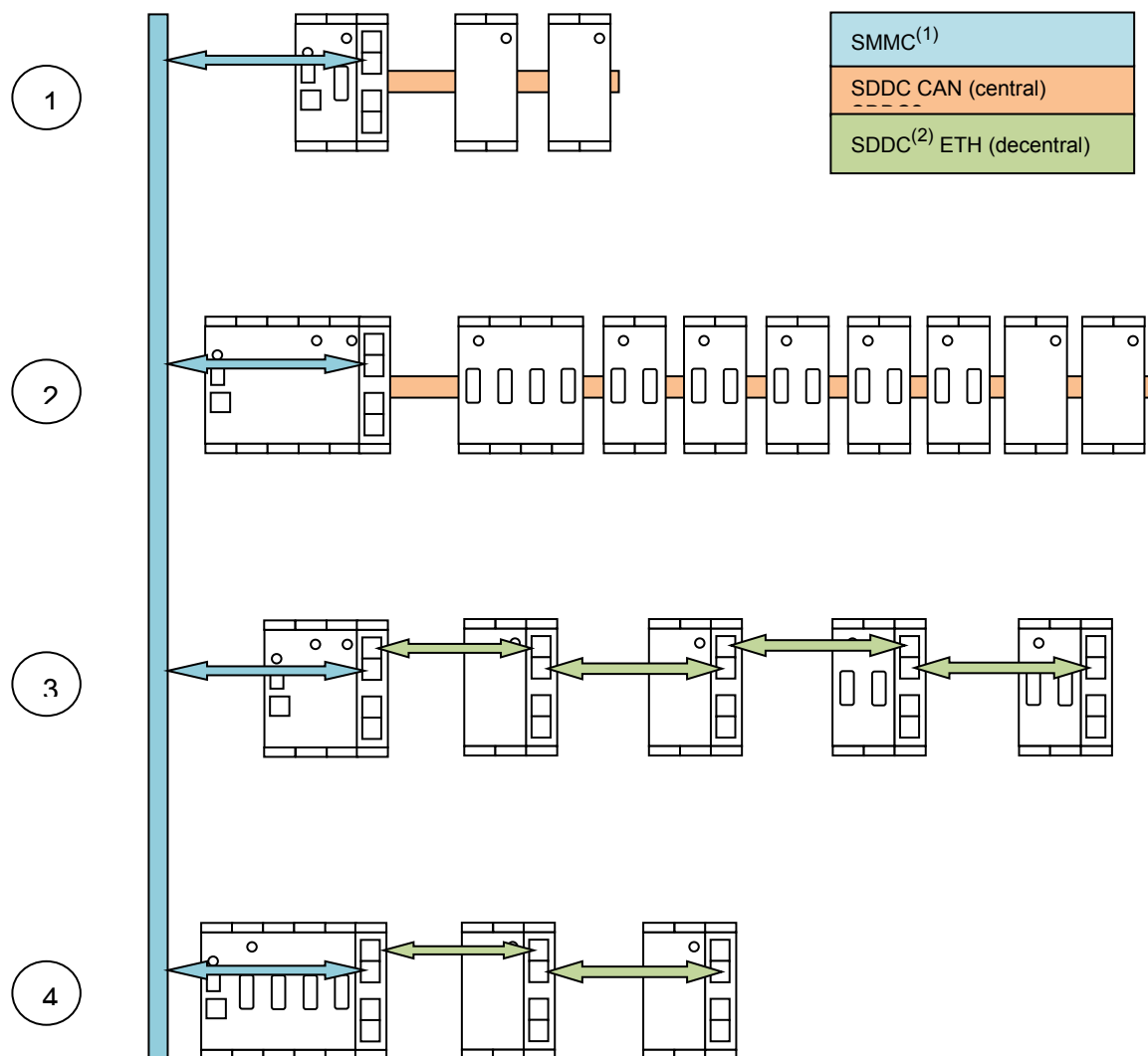

1	Communication of a PSC1 compact with <ul style="list-style-type: none"> • Central expansion modules via SDDC CAN backplane bus • SMMC⁽¹⁾ via Ethernet
2	Communication of a PSC1 modular with <ul style="list-style-type: none"> • Central expansion modules via SDDC CAN backplane bus • SMMC⁽¹⁾ via Ethernet
3	Communication of a PSC1 modular with <ul style="list-style-type: none"> • Decentral expansion module via SDDC⁽²⁾ Ethernet • SMMC⁽¹⁾ via Ethernet • A switch is required in the configuration shown
4	Communication of a PSC1 compact with <ul style="list-style-type: none"> • Decentral expansion modules via SDDC⁽²⁾ Ethernet • SMMC⁽¹⁾ via Ethernet

Options:

- (1) SMMC on request
- (2) SDDC in preparation

5.6 Installation of I/O expansion

Note:

Max. two PSC1-E-3x modules can be operated using a basic device.

5.6.1.1 Physical address configuration for the slave modules (central / decentral)

The bus address must be set on the PSC1-E-3x modules with the aid of the address switch.

The address is set on the rear panel depending on the slot (mounting position) of the module.

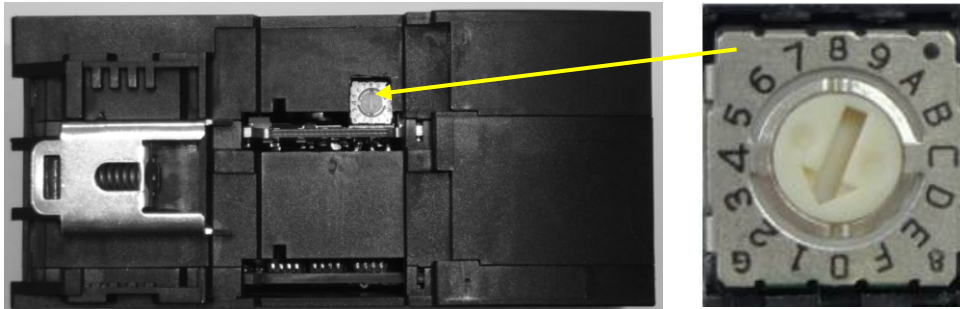

Note:

- Address range on the PSC1-E-3x module is 1 or 2.
- Address "0" is reserved for the basic device.
- Factory setting of all expansion modules: 1

5.7 Terminal assignment

Attention! Identifiers for "Xxy" terminal blocks e.g. X11 are not printed on the terminal blocks. They are used in this Section to find the individual terminals more quickly, e.g. "A1.1" in the diagrams and the terminal assignment.

5.7.1 Terminal assignment PSC1-C-10 (-FBx/-MC)

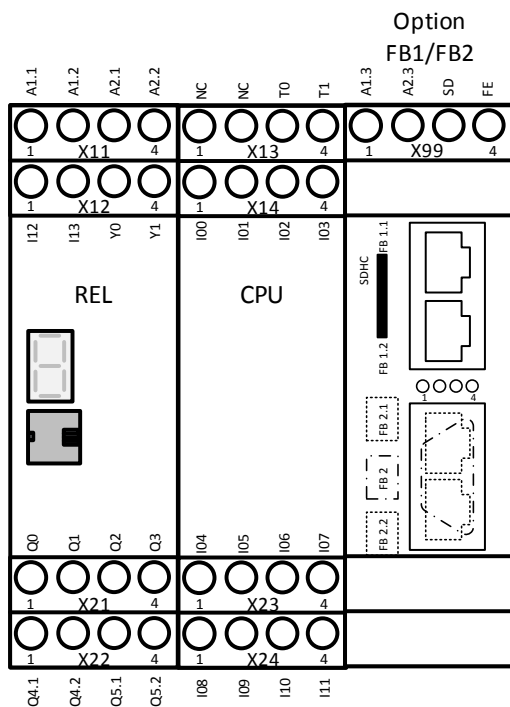

Terminal assignment					
Unit	Terminal	Pin	Description	Note	
REL	X11	1 – A1.1	Device power supply +24 VDC		
		2 – A1.2	Device power supply +24 VDC outputs		
		3 – A2.1	Device power supply 0 VDC		
		4 – A2.2			
	X12	1 – I 12	Safe digital inputs		
		2 – I 13			
		3 – Y0	Signal outputs		
		4 – Y1			
	X21	1 – Q0	Output pn switching Q0_PP / pp switching Q0	optionally can be configured in the parameters via SafePLC2	
		2 – Q1	Output pn switching Q1_PN / pp switching Q1		
		3 – Q2	Output pn switching Q2_PP / pp switching Q2		
		4 – Q3	Output pn switching Q3_PN / pp switching Q3		
X22	1 – Q4.1	Safe relay output			
	2 – Q4.2				
	3 – Q5.1	Safe relay output			
	4 – Q5.2				
CPU	X13	1 – NC	No function		
		2 – NC			
		3 – T0		Pulse outputs	
		4 – T1			
	X14	1 – I 00	Safe digital inputs		
		2 – I 01			
		3 – I 02			
		4 – I 03			
	X23	1 – I 04			
		2 – I 05			
		3 – I 06			
		4 – I 07			
	X24	1 – I 08			
		2 – I 09			
		3 – I 10			
		4 – I 11			

Option FB1/FB2	X99	1 – A1.3	Power supply SD-Bus +24 V DC	
		2 – A2.3	Power supply SD-Bus 0 V DC	
		3 – SD	SD-Bus connection	
		4 – FE	Functional earth	Connect to FE or PE of the control cabinet (use short cables)

5.7.2 Terminal assignment PSC1-C-10-SDM1 (-FBx/-MC)

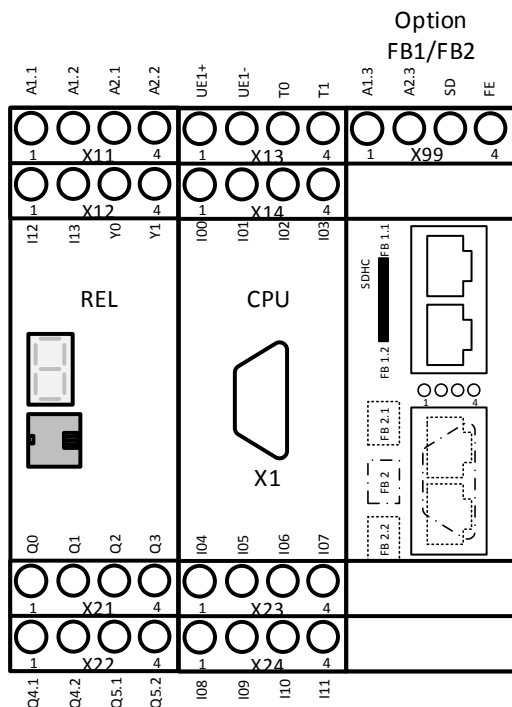

Terminal assignment				
Unit	Terminal	Pin	Description	Note
REL	X11	1 – A1.1	Device power supply +24 VDC	
		2 – A1.2	Device power supply +24 VDC outputs	
		3 – A2.1	Device power supply 0 VDC	
		4 – A2.2		
	X12	1 – I12	Safe digital inputs	
		2 – I13		
		3 – Y0	Signal outputs	
		4 – Y1		
	X21	1 – Q0	Output pn switching Q0_PP / pp switching Q0	optionally can be configured in the parameters via SafePLC2
		2 – Q1	Output pn switching Q1_PN / pp switching Q1	
		3 – Q2	Output pn switching Q2_PP / pp switching Q2	
		4 – Q3	Output pn switching Q3_PN / pp switching Q3	
X22	1 – Q4.1	Safe relay output		
	2 – Q4.2			
	3 – Q5.1	Safe relay output		
	4 – Q5.2			
CPU-ENC	X13	1 – UE1+	Encoder power supply DC (X1)	
		2 – UE1-	Encoder power supply 0V DC (X1)	
		3 – T0	Pulse outputs	
		4 – T1		
	X14	1 – I00	Safe digital inputs	
		2 – I01		
		3 – I02		
		4 – I03		
	X23	1 – I04		
		2 – I05		
		3 – I06		
		4 – I07		
	X24	1 – I08		
		2 – I09		
		3 – I10		
		4 – I11		

Option FB1/FB2	X99	1 – A1.3	Power supply SD-Bus +24 V DC	
		2 – A2.3	Power supply SD-Bus 0 V DC	
		3 – SD	SD-Bus connection	
		4 – FE	Functional earth	Connect to FE or PE of the control cabinet (use short cables)

5.7.3 Terminal assignment PSC1-C-10-SDM2 (-FBx/-MC)

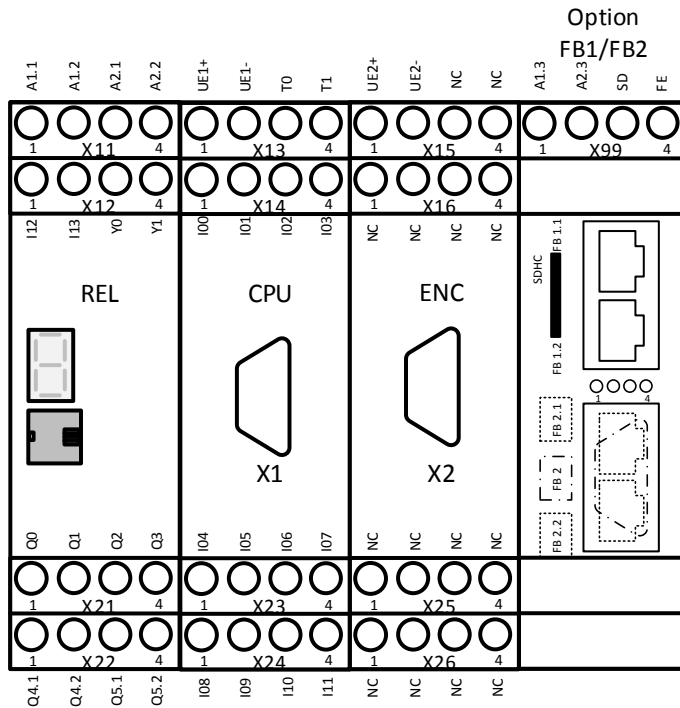

Terminal assignment					
Unit	Terminal	Pin	Description	Note	
REL	X11	1 – A1.1	Device power supply +24 VDC		
		2 – A1.2	Device power supply +24 VDC outputs		
		3 – A2.1	Device power supply 0 VDC		
		4 – A2.2			
	X12	1 – I 12	Safe digital inputs		
		2 – I 13			
		3 – Y0	Signal outputs		
		4 – Y1			
	X21	1 – Q0	Output pn switching Q0_PP / pp switching Q0		optionally can be configured in the parameters via SafePLC2
		2 – Q1	Output pn switching Q1_PN / pp switching Q1		
		3 – Q2	Output pn switching Q2_PP / pp switching Q2		
		4 – Q3	Output pn switching Q3_PN / pp switching Q3		
X22	1 – Q4.1	Safe relay output			
	2 – Q4.2				
	3 – Q5.1	Safe relay output			
	4 – Q5.2				
CPU-ENC	X13	1 – UE1+	Encoder power supply DC (X1)		
		2 – UE1-	Encoder power supply 0V DC X1		
		3 – T0	Pulse outputs		
		4 – T1			
	X14	1 – I 00	Safe digital inputs		
		2 – I 01			
		3 – I 02			
		4 – I 03			
	X23	1 – I 04			
		2 – I 05			
		3 – I 06			
		4 – I 07			
	X24	1 – I 08			
		2 – I 09			
		3 – I 10			
		4 – I 11			

Terminal assignment				
Unit	Terminal	Pin	Description	Note
ENC	X15	1 – UE1+	Encoder power supply DC (X2)	
		1 – UE1-	Encoder power supply 0V DC (X2)	
		3 – NC	No function	
		4 – NC	No function	
	X16	1 – NC	No function	
		2 – NC	No function	
		3 – NC	No function	
		4 – NC	No function	
	X25	1 – NC	No function	
		2 – NC	No function	
		3 – NC	No function	
		4 – NC	No function	
	X26	1 – NC	No function	
		2 – NC	No function	
		3 – NC	No function	
		4 – NC	No function	
Option FB1/FB2	X99	1 – A1.3	Power supply SD-Bus +24 V DC	
		2 – A2.3	Power supply SD-Bus 0 V DC	
		3 – SD	SD-Bus connection	
		4 – FE	Functional earth	Connect to FE or PE of the control cabinet (use short cables)

5.7.4 Terminal assignment PSC1-E-31

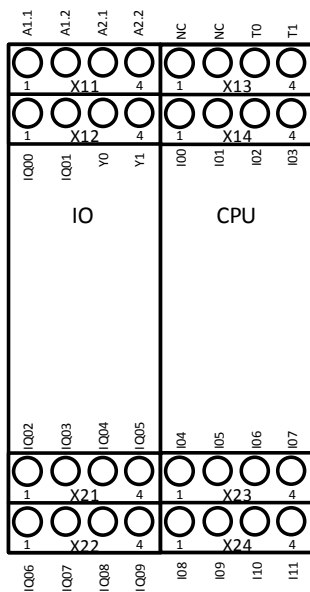

Terminal assignment					
Unit	Terminal	Pin	Description	Note	
IO	X11	1 – A1.1	Device power supply +24 V DC	Attention: see: "External 24 VDC power supply"	
		2 – A1.2	Device power supply +24 V DC		
		3 – A2.1	Device power supply 0V DC		
		4 – A2.2			
	X12	1 – IQ 00	Safe digital inputs, outputs pp switching		
		2 – IQ 01			
		3 – Y0	Signal outputs		
		4 – Y1			
	X21	1 – IQ 02	Safe digital inputs, outputs pp switching		
		2 – IQ 03			
		3 – IQ 04			
		4 – IQ 05			
X22	1 – IQ 06				
	2 – IQ 07				
	3 – IQ 08				
	4 – IQ 09				
CPU	X13	1 – NC	No function		
		2 – NC			
		3 – T0	Pulse outputs		
		4 – T1			
	X14	1 – I 00	Safe digital inputs		
		2 – I 01			
		3 – I 02			
		4 – I 03			
	X23	1 – I 04			
		2 – I 05			
		3 – I 06			
		4 – I 07			
	X24	1 – I 08			
		2 – I 09			
		3 – I 10			
		4 – I 11			

5.7.5 Terminal assignment PSC1-E-33

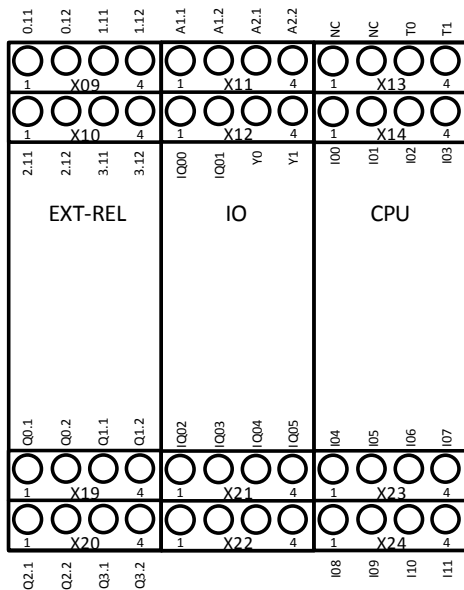

Note:

The read-back contacts 0.11/12, 1.11/12, 2.11/12, 3.11/12 of the internal relays Q0, Q1, Q2, Q3 must be monitored for feedback loop monitoring (EMU) in addition to the read-back contacts of the connected contactors or other switching amplifiers.

Terminal assignment				
Unit	Terminal	Pin	Description	Note
EXT-REL	X09	1 – 0.11	Readback contact relay 1	
		2 – 0.12	Readback contact relay 1	
		3 – 1.11	Readback contact relay 2	
		4 – 1.12	Readback contact relay 2	
	X10	1 – 2.11	Readback contact relay 3	
		2 – 2.12	Readback contact relay 3	
		3 – 3.11	Readback contact relay 4	
		4 – 3.12	Readback contact relay 4	
	X19	1 – Q0.1	Safe relay output 1 (1-channel)	
		2 – Q0.2	Safe relay output 1 (1-channel)	
		3 – Q1.1	Safe relay output 2 (1-channel)	
		4 – Q1.2	Safe relay output 2 (1-channel)	
X20	1 – Q2.1	Safe relay output 3 (1-channel)		
	2 – Q2.2	Safe relay output 3 (1-channel)		
	3 – Q3.1	Safe relay output 4 (1-channel)		
	4 – Q3.2	Safe relay output 4 (1-channel)		
IO	X11	1 – A1.1	Device power supply +24 V DC	Attention: see: "External 24 VDC power supply"
		2 – A1.2	Device power supply +24 V DC	
		3 – A2.1	Device power supply 0V DC	
		4 – A2.2		
	X12	1 – IQ 00	Safe digital inputs, outputs pp switching	
		2 – IQ 01		
		3 – Y0	Signal outputs	
		4 – Y1		
	X21	1 – IQ 02	Safe digital inputs, outputs pp switching	
		2 – IQ 03		
		3 – IQ 04		
		4 – IQ 05		
	X22	1 – NC	No function	
		2 – NC		
		3 – NC		
		4 – NC		

Terminal assignment				
Unit	Terminal	Pin	Description	Note
CPU	X13	1 – NC	No function	
		2 – NC		
		3 – T0	Pulse outputs	
		4 – T1		
	X14	1 – I 00	Safe digital inputs	
		2 – I 01		
		3 – I 02		
		4 – I 03		
	X23	1 – I 04		
		2 – I 05		
		3 – I 06		
		4 – I 07		
	X24	1 – I 08		
		2 – I 09		
		3 – I 10		
		4 – I 11		

5.7.6 Terminal assignment PSC1-E-37 in preparation

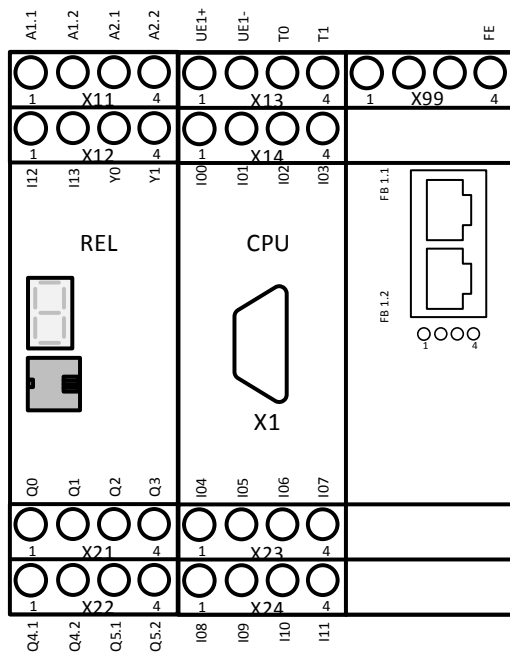

Terminal assignment				
Unit	Terminal	Pin	Description	Note
REL	X11	1 – A1.1	Device power supply +24 VDC	
		2 – A1.2	Device power supply +24 VDC outputs	
		3 – A2.1	Device power supply 0 VDC	
		4 – A2.2		
	X12	1 – I 12	Safe digital inputs	
		2 – I 13	Signal outputs	
		3 – Y0		
		4 – Y1		
	X21	1 – Q0	Output pn switching Q0_PP / pp switching Q0	optionally can be configured in the parameters via SafePLC2
		2 – Q1	Output pn switching Q1_PN / pp switching Q1	
		3 – Q2	Output pn switching Q2_PP / pp switching Q2	
		4 – Q2	Output pn switching Q3_PN / pp switching Q3	
X22	1 – Q4.1	Safe relay output		
	2 – Q4.2	Safe relay output		
	3 – Q5.1			
	4 – Q5.2			
CPU	X13	1 – NC	No function	
		2 – NC	Pulse outputs	
		3 – T0		
		4 – T1		
	X14	1 – I 00	Safe digital inputs	
		2 – I 01		
		3 – I 02		
		4 – I 03		
	X23	1 – I 04		
		2 – I 05		
		3 – I 06		
		4 – I 07		
X24	1 – I 08			
	2 – I 09			
	3 – I 10			
	4 – I 11			
X99	1 – NC	No function		
	2 – NC			
	3 – NC			
	4 – FE	Functional earth	Connect to FE or PE of the control cabinet (use short cables)	

5.7.7 Terminal assignment PSC1-C-10(-SDMx)-FBx

Please refer to the installation manual for PSC1 fieldbuses for the terminal assignments of the fieldbus or SDDC/SMMC interfaces of the various communication modules.

5.8 External 24 VDC power supply

The PSC1 module requires a power supply of 24 VDC (on this topic see SELV or PELV, EN50178). During the planning and installation of the power supply unit to be used, attention is to be paid to the following boundary conditions:

It is imperative the minimum and maximum tolerance on the supply voltage is observed.

Nominal voltage	DC 24 V
Minimum: 24 VDC – 15%	20.4 VDC
Maximum: 24 VDC + 20%	28.8 VDC

To achieve residual ripple on the supply voltage as low as possible, the usage of a 3-phase power supply unit or an electronically regulated unit is recommended. The power supply unit must satisfy the requirements according to EN61000-4-11 (voltage drop). The connection cable must be designed according to the local regulations. The PSC1 module can withstand an external voltage of 32 VDC (protected by suppressor diodes on the input).

Safety instructions:

- The PSC1 module must be fused individually according to the data sheet. Recommended type: single-pole thermo-magnetic circuit breaker with fast characteristic

Remark:

In all circumstances, safe electrical isolation on relation to 230 VAC or 400 VAC mains must be ensured. For this purpose power supply units are to be selected that satisfy the standards DIN VDE 0551, EN 60 742 and DIN VDE 0160. Along with the selection of a suitable unit, attention is to be paid to equipotential bonding between PE and 0 VDC on the secondary side.

Safety instructions:

- All GND connections on the devices that are connected to the inputs on the PSC1 module must be connected to GND on the PSC1 (power supply).

Inputs on the PSC1 are:

- Digital inputs
- Digital I/O
- Analogue inputs (on request)
- Encoder connections

Remark:

The GND_ENC connection is not connected internally to GND!

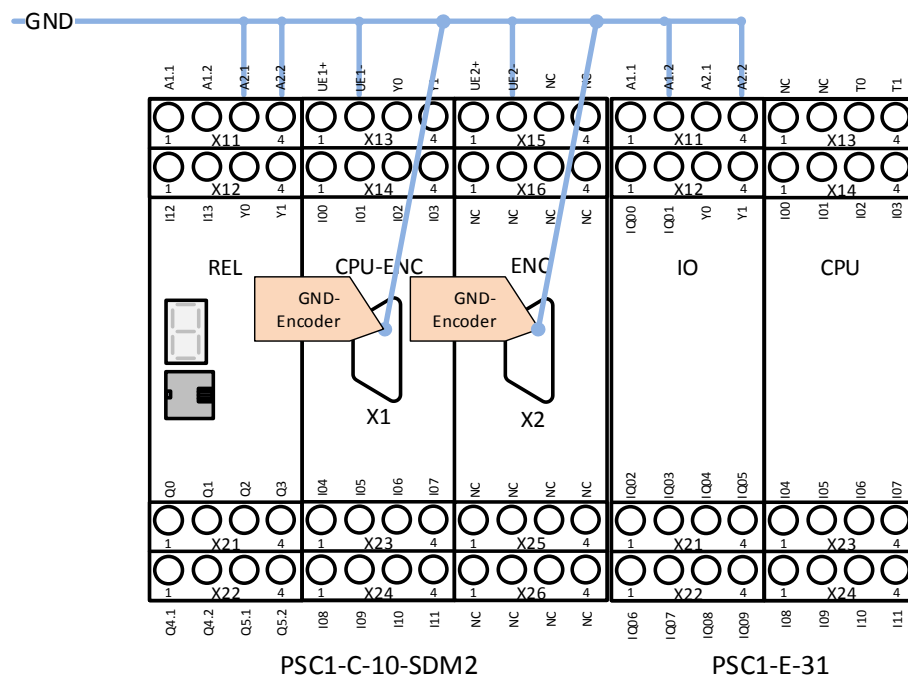

5.9 Connection of the external encoder supply

5.9.1 Incremental, HTL (on request), SIN/COS, SSI

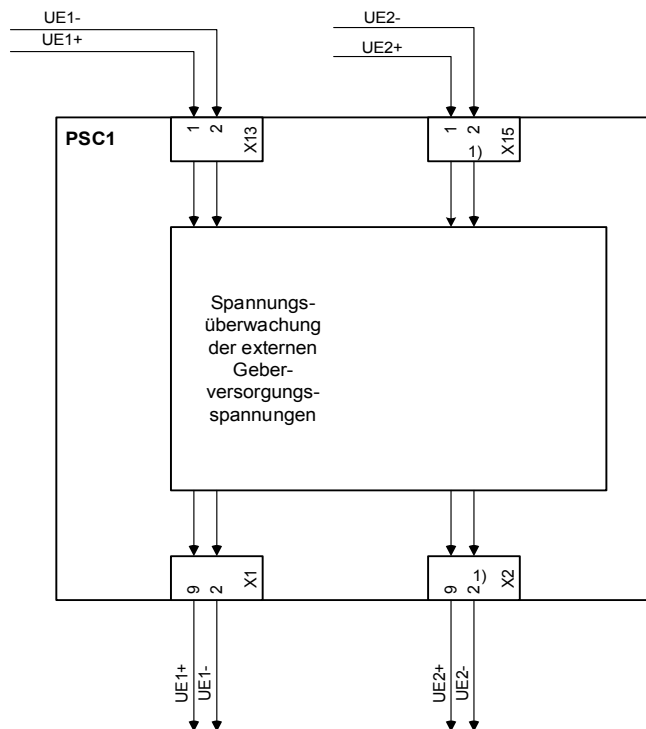

Options:

¹⁾ Only PSC1-C-10-SDM2

The PSC1 module supports encoder voltages of 5V, 8V, 10 V, 12V, 20V and 24V that are monitored internally as per the configuration selected.

If an encoder system is not supplied via the PSC1 module, a supply of power must still be connected to terminal X13 and X15 and configured appropriately.

The encoder supply is to be protected with maximum 2 A.

Safety instructions:

- The GND connection for the encoder must be connected to GND on the PSC1

Monitoring of the supply voltage as per the nominal voltage selected:

Nominal voltage	Minimum voltage	Maximum voltage
5 VDC	4.4 VDC	5.6 VDC
8 VDC	7 VDC	9 VDC
10 VDC	8 VDC	12 VDC
12 VDC	10 VDC	14 VDC
20 VDC	16 VDC	24 VDC
24 VDC	20 VDC	29.5 VDC

5.10 Connection of the digital inputs

- The PSC1 has 14 (PSC1-C-10(-SDMX)(-FBx) and PSC1-E-37) or 12 (PSC1-E-31/33) safe digital inputs. These are suitable for the connection of single or dual-channel signals with and without test pulses, or without cross-circuit testing.
- The signals connected must have a "high" level of DC 24 V (DC +15 V...+ DC 30 V) and a "low" level of (DC -3 V... DC +5 V, type 1 according to EN61131-2). The inputs are equipped internally with input filters.
- The device-internal diagnostic function cyclically checks the correct function of the inputs including the input filter. The detection of a fault places the PSC1 in the alarm state. At the same time all outputs on the PSC1 are rendered passive.
- Along with the actual signal inputs, the PSC1 module provides two pulse outputs T0 and T1. The pulse outputs are switching 24 VDC outputs.
- The pulse outputs are only intended to be used for monitoring the digital inputs (I0 ... I13) and cannot be used for any other functions in the application.
- The switching frequency is 125 Hz for each pulse output. During planning it is to be noted that the pulse outputs are allowed to be loaded with a maximum total current of 250 mA.
- In addition, approved OSSD outputs can be connected to the inputs I00-I13 without restriction.
- On the single-channel usage of the inputs, the safety level that can be achieved is limited to SIL 2 or PL d, if there is no demand for the safety function at regular intervals.
- In principle, safety-related usage of the inputs is only intended in conjunction with the pulse outputs.
- If the pulse outputs are not used, a short-circuit in the external wiring between different inputs and the supply voltage for the PSC1 must be excluded by means of suitable external measures, in particular suitable cable routing.
- Each input on the PSC1 module can be configured individually for the following signal sources:
 - Input is assigned pulse T0
 - Input is assigned pulse T1
 - Input is assigned DC 24 V continuous voltage

5.11 Connection of position and speed sensors

5.11.1 General instructions

Depending on the module type, the PSC1 module (PSC1-C-10-SDMx) has external encoder interfaces for the connection of the usual industrial incremental and absolute encoders. The encoder interfaces can be configured for incremental, SIN/COS, absolute SSI encoders or for proximity switches.

In addition, it is possible to connect two sensors that generate incremental signals (for instance proximity switches or HTL signals) to the counter inputs on the PSC1 module. The signals must be read using a normal track and a complementary track.

IMPORTANT:

Power is supplied to the encoder system via the terminals provided on the PSC1 module. This voltage is supplied to the encoder connector and is monitored by an internal diagnostic process.

If the sensor is supplied with an external voltage, this must be routed via the encoder connector. The related terminal (encoder power supply) on the PSC1 module remains unused.

If an external sensor supply voltage is not fed back via the encoder connector, the failure of this supply is to be included in the fault analysis for the overall system. In particular, it is therefore necessary to demonstrate that if the specified operating voltage for the encoder system is dropped below / exceeded, this fault will be detected or can be excluded.

EMC measures such as screening etc. are to be observed.

The two encoders must not interact with each other. This applies for both the electrical and the mechanical part.

If both encoders are coupled to the device to be monitored via common mechanical parts, the connection must be of a positively locking design and there must not be any parts subject to wear (chains, toothed belts etc.). If this is nevertheless the case, additional monitoring devices for the mechanical connection of the sensors are required (e.g. monitoring a toothed belt).

If position processing is active, at least one absolute encoder must be used.

On the usage of two equivalent sensors it is to be ensured that the sensor with the higher resolution is configured as sensor1 (process sensor) and the sensor with the lower resolution as sensor 2 (reference sensor).

⚠ Safety instructions:

- The GND connections for the encoders are to be connected to GND on the PSC1.

Attention:

The encoder connections are not allowed to be connected or disconnected in operation. Electrical components on the encoder may be irreparably damaged. Disconnect from the electrical supply the encoders connected and the PSC1 module **before** connecting or disconnecting the encoder connections. For externally supplied encoders, pay attention to shutting down the external supply voltage (e.g. converter)

Twisted pairs according to the RS485 standard are to be used for signal transmission for the data and clock signals or track A and track B. On the selection of the cross-section of the wire, the current consumption of the encoder and the cable length in the installation in the specific case are to be taken into account.

On the usage of absolute encoders, the following also applies:

In the slave mode, the clock signal is generated by an external process and is read with the data signal from the PSC1 module. Due to this type of sampling there is a beat and as a consequence a sampling error of the following order of magnitude:

$$F = (\text{encoder sampling time, external system [ms]} / 8 [\text{ms}]) * 100 \%$$

The magnitude of the sampling error produced F must be taken into account on defining the thresholds on the monitoring functions used, as this error cannot be compensated!

5.11.2 Encoder interface assignment

X1/X2¹⁾

Sensorbelegung

Incremental - Encoder

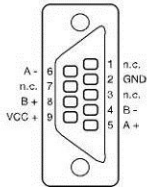

SIN/COS

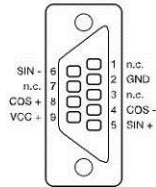

Absolut - Encoder

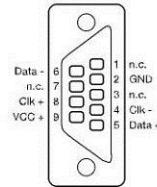

SSI - Listener

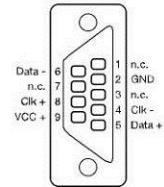

Options:

1) only PSC1-C-10-SDM2

5.11.3 Connection variants

5.11.3.1 Connection of an absolute encoder as master

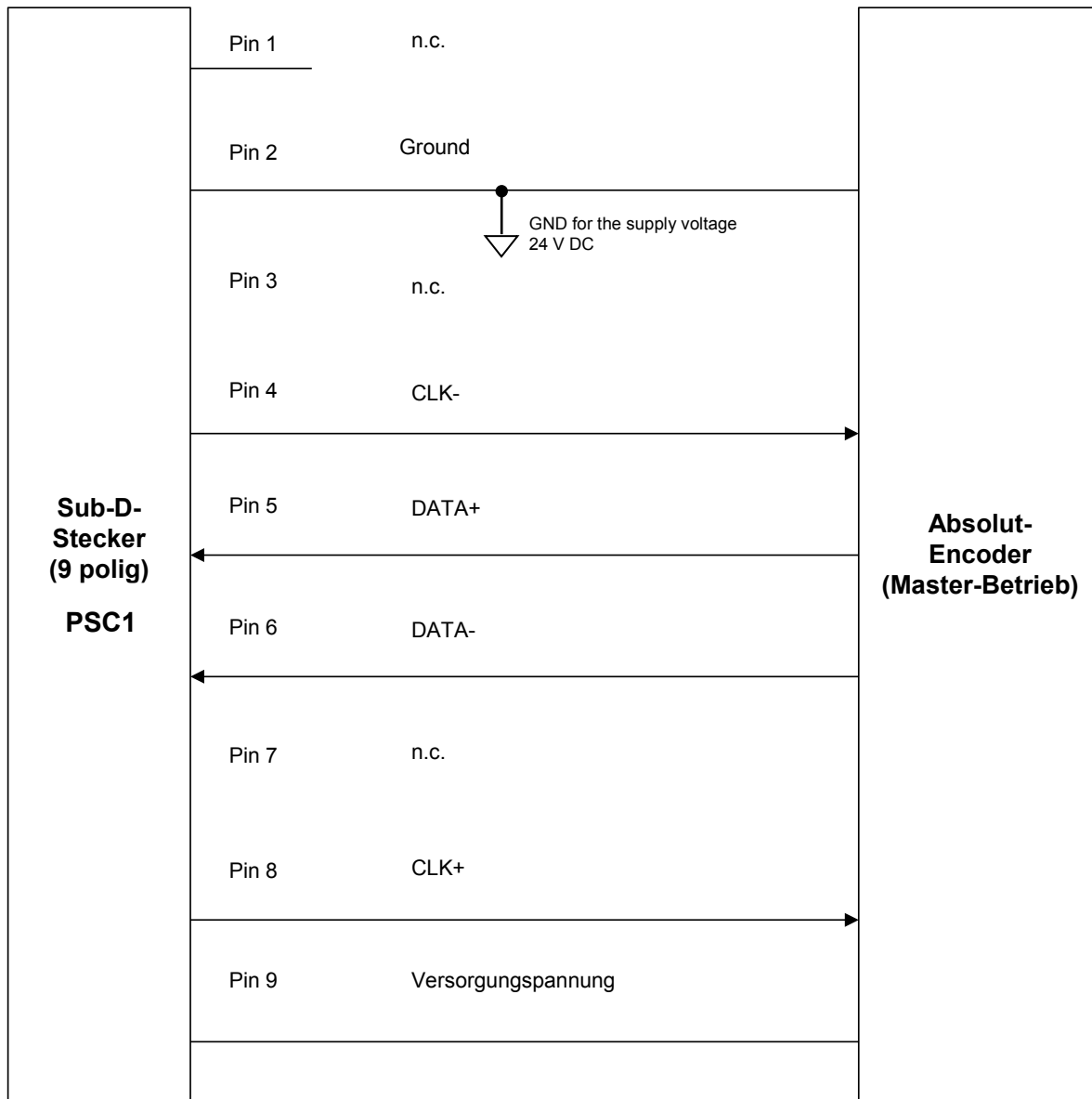

With this type of connection, the clock signals pass from the PSC1 module to the absolute encoder and the data from the encoder to the PSC1.

5.11.3.2 Connection of an absolute encoder as slave

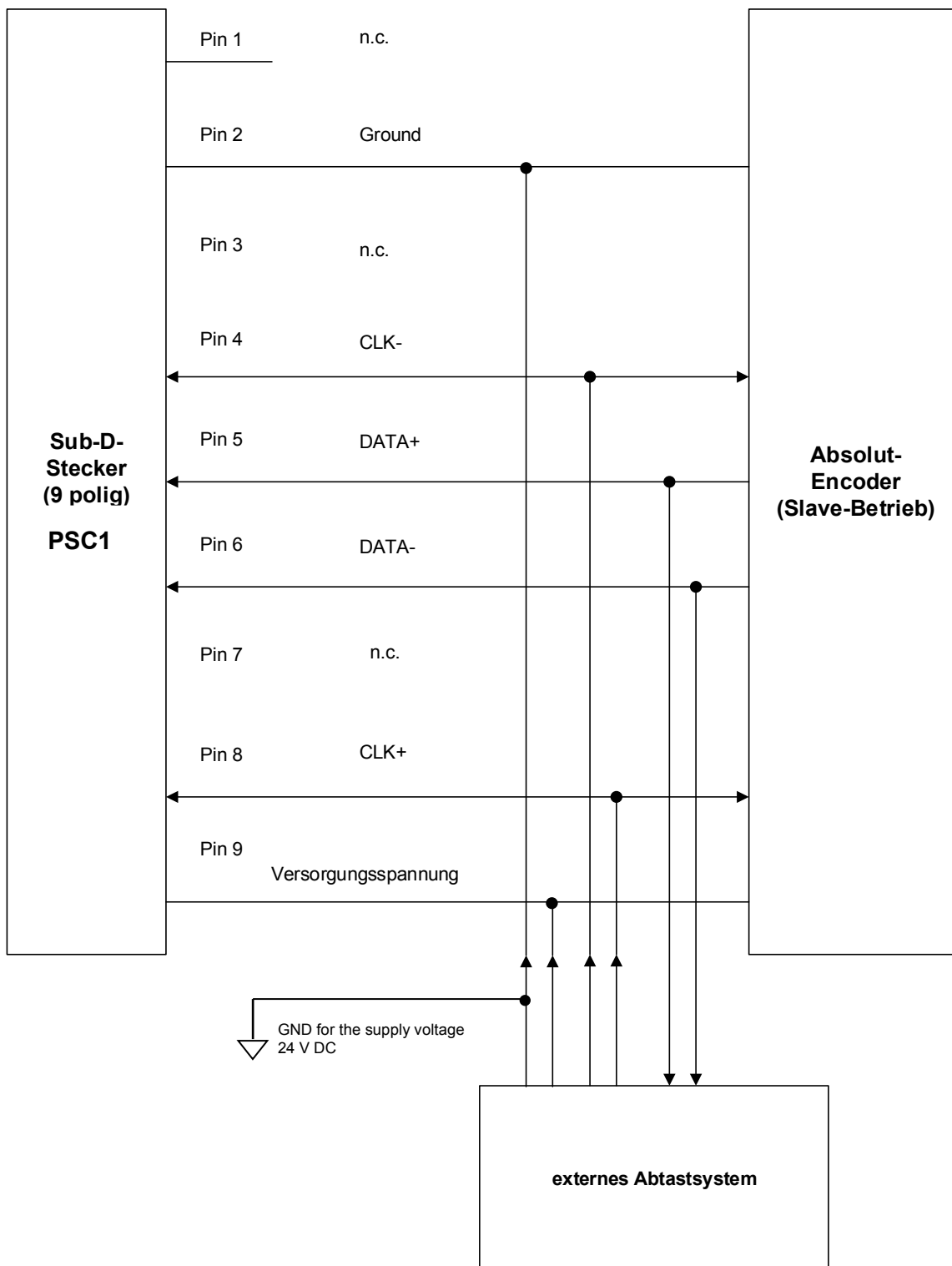

With this type of connection, the clock signals and the data are read together. In this example the encoder is not supplied with power from the module.

5.11.3.3 Connection of an incremental encoder with TTL signal level

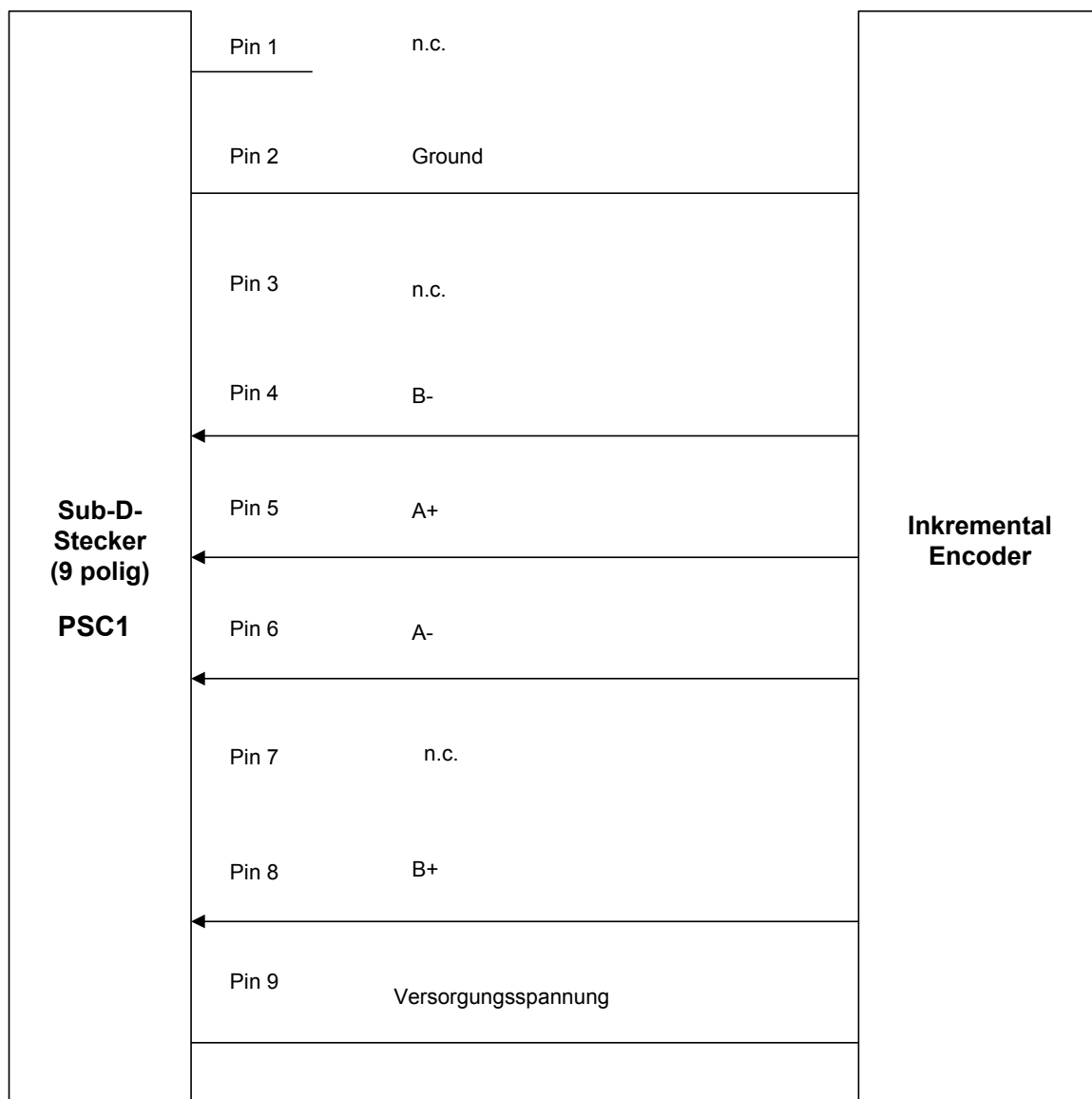

Pins 1, 3 and 7 remain open and are reserved for later expansions.

5.11.3.4 Connection of a SIN/COS encoder

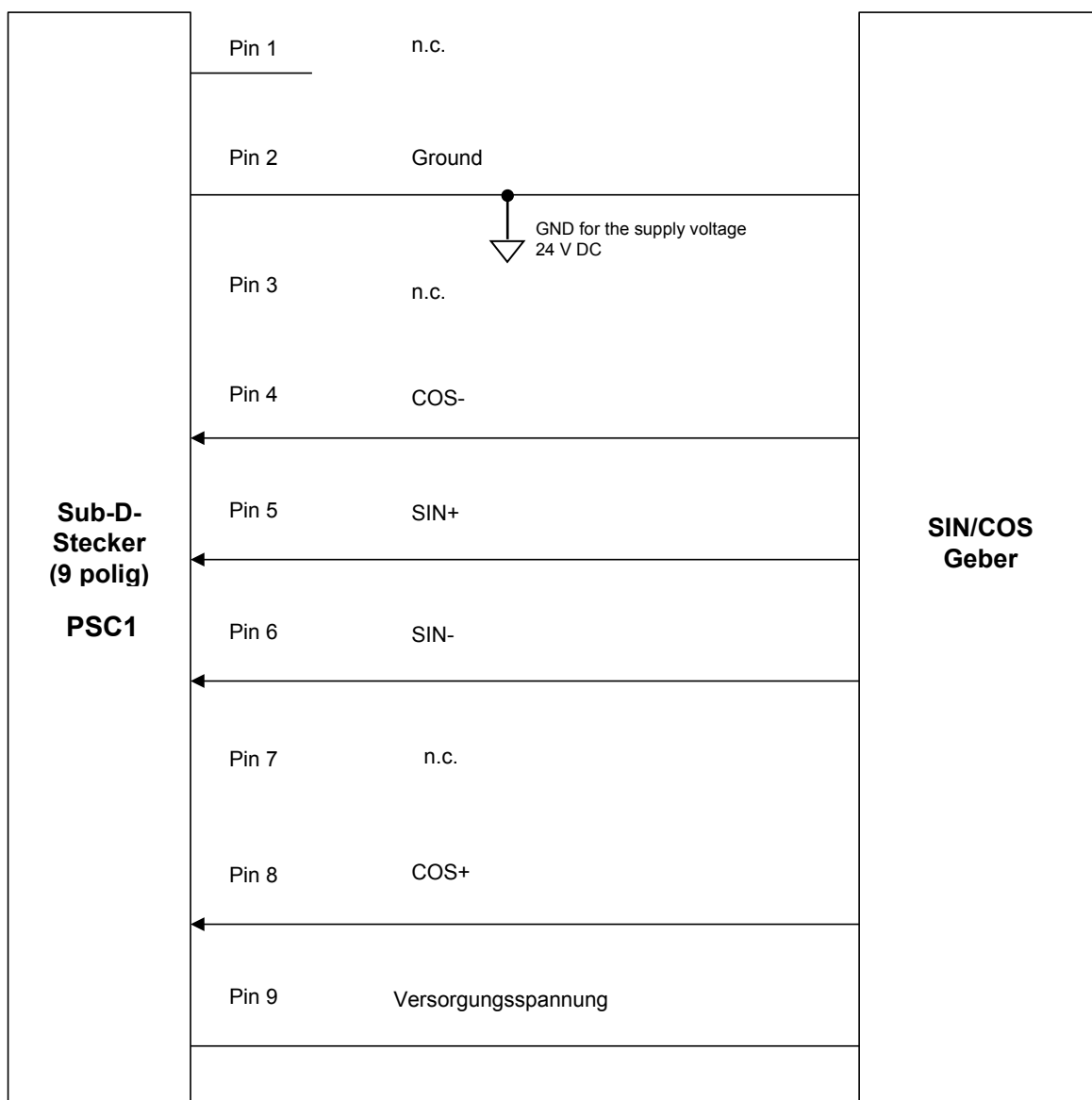

Pins 1, 3 and 7 remain open and are reserved for later expansions.

5.11.3.5 Connection of proximity switch PSC1-C-10-SDM1/2

Connection is via the connector X23 to the digital inputs I04 ... I07.

The exact pin assignment is dependent on which encoder type is used and is given in the connection diagram in the programming software user interface.

Note:

On the usage of HTL encoder, it is to be noted that the tracks A+ and B+ or A- and B- must be combined correspondingly.

5.12 Configuration of the measurement sections

5.12.1 General description of the encoder configuration

The most important input variables for the module's monitoring functions are safe position, speed and acceleration. These are generated from the sensor systems connected using two channels. For PL e according to EN ISO 13849-1 an architecture corresponding to category 4, i.e. continuous dual-channel acquisition with high diagnostic coverage is required. For all single-channel portions (e.g. mechanical connection of the sensor/encoder with only one shaft/fastening) justified fault exclusions according to EN ISO 13849-2 can be defined. For PL d according to EN ISO 13849-1, reduced diagnostic coverage can be used. Taking into account the permissible fault exclusions according to EN ISO 13849-2, in some circumstances sensor systems with a simple layout (only speed monitoring) may be adequate. On this topic see APPENDIX 1

Note:

Further configuration is described in the programming manual.

5.12.2 Sensor type

Absolute encoders and incremental measuring systems are possible as well as proximity switches that generate a count pulse.

5.12.2.1 Absolute encoder

Data interface: Serial Synchronous Interface (SSI) with variable data length from 12 to 28 bits
 Data format: Binary or Gray code
 Physical layer: RS-422 compatible

SSI master operation:

Clock rate: 150kHz

SSI listener operation (slave operation):

Max. external clock rate: 200 KHz ¹⁾ or 350 kHz ²⁾.
 Min. pulse pause time: 30 µsec
 Max. pulse pause time: 1 ms

Diagnostics:

Diagnosics	Parameter	Fault threshold
Supply voltage monitoring	Fixed values 5 V, 8 V, 10 V, 12 V, 20 V, 24 V	See section 5.9.1
Monitoring differential level on the input	Fixed value RS 485 level	+/- 20% +/-2% (measuring tolerance)
CLK frequency monitoring	Fixed value	100 kHz < f < 350 kHz
Plausibility of speed versus position	Fixed value	$\Delta P < 2 * V * T$ with T = 8 ms

SSI format parameter configuration:

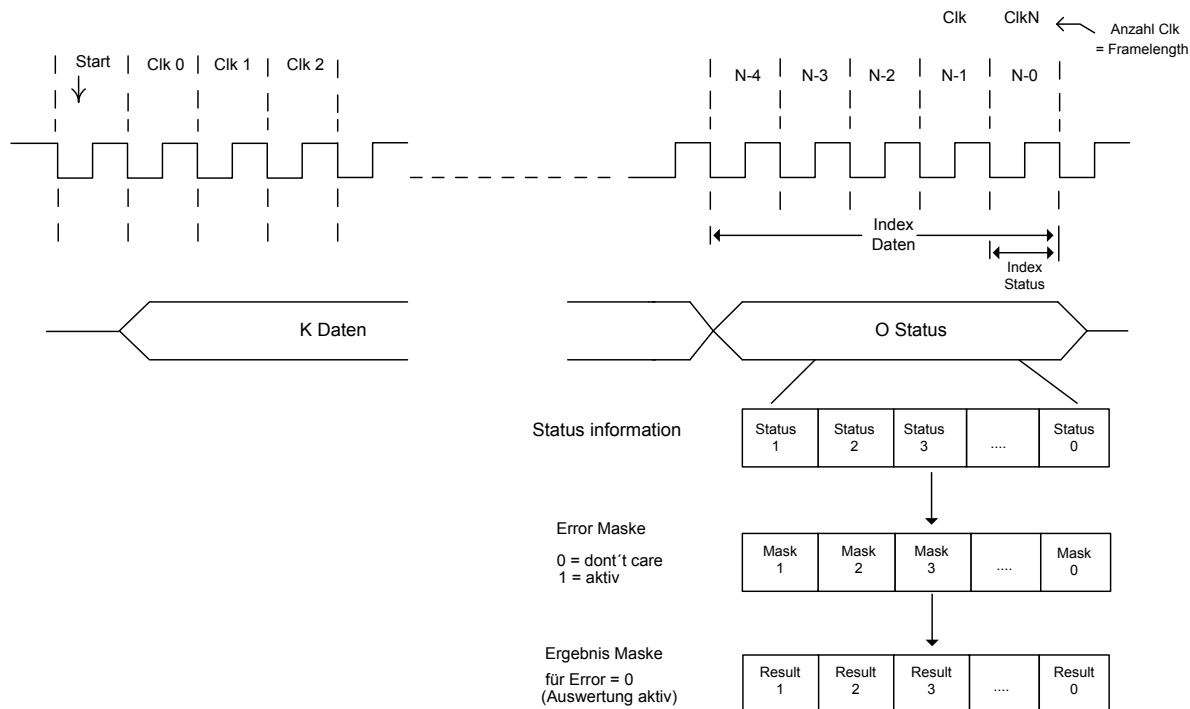

Example:

SSI-Frame length: 28 pulses
 Data length: 22 bits
 Status: 5 bits, 3 bits error + 2 bits warning/ready for operation

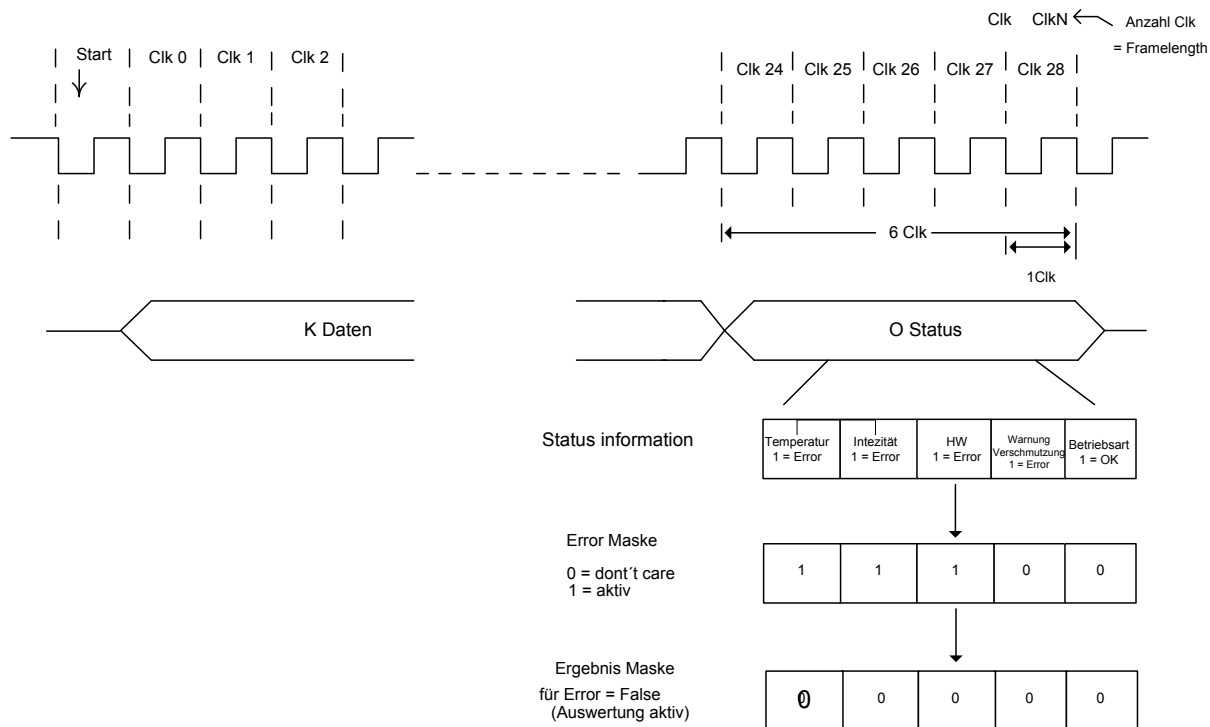

5.12.2.2 Incremental encoder

Physical layer: RS-422 compatible
 Measured signal A/B: Track with 90 degree phase difference
 Maximum input pulse frequency: 200 kHz ⁽¹⁾ or 500 kHz ⁽²⁾

Options:

- (1) Standard incremental
- (2) HighRes incremental (on request);

Diagnostics:

Diagnosics	Parameter	Fault threshold
Supply voltage monitoring	Fixed values 5 V, 8 V, 10 V, 12 V, 20 V, 24 V	See section 5.9.1 Incremental, HTL (on request), SIN/COS, SSI
Monitoring differential level on the input	Fixed value RS 485 level	+/- 20% +/-2% (measuring tolerance)
Monitoring of the count signal separately for each track A/B	Fixed value	$\Delta P > 4$ increments

5.12.2.3 SineCosine encoder – standard mode

Physical layer: +/- 0.5 Vpp (without voltage offset)
 Measured signal A/B: Track with 90 degree phase difference
 Maximum input pulse frequency: 200 kHz ⁽¹⁾ or 500 kHz ⁽²⁾

Options:

- (1) like Standard incremental
- (2) HighRes Sin/Cos (on request);

Diagnostics:

Diagnosics	Parameter	Fault threshold
Supply voltage monitoring	Fixed values 5 V, 8 V, 10 V, 12 V, 20 V, 24 V	See section 5.9.1 Incremental, HTL (on request), SIN/COS, SSI
SIN ² +COS ² amplitude monitoring	Fixed value 1V _{pp}	65% or 1 V _{pp} +/- 2.5% (measuring tolerance)
Monitoring of phase A/B	Fixed value 90°	+/- 30° +/-5° measuring tolerance)

5.12.2.4 proximity switches

Signal level: 24 V/0 V
 Max. count pulse frequency: 10 kHz
 Min. count pulse frequency: 4 Hz
 De-bounced switching logic

Diagnostics:

Diagnosics	Parameter	Fault threshold
Monitoring of supply voltage not possible	-	-

5.12.2.5 Extended monitoring with 2 proximity switches

The expanded monitoring detects the following faults:

- a) Failure of the supply voltage
- b) Failure of the output signal in the driver direction
- c) Proximity switch functional failure for high signal
- d) Signal path interruption
- e) Mechanical maladjustment of proximity switch / excessively large proximity switching distance

For the diagnostics the two status conditions of the count signals are additionally acquired synchronously and compared logically. A switch gate must be used to ensure that at least one of the two signals is actuated. The logic evaluates this rule.

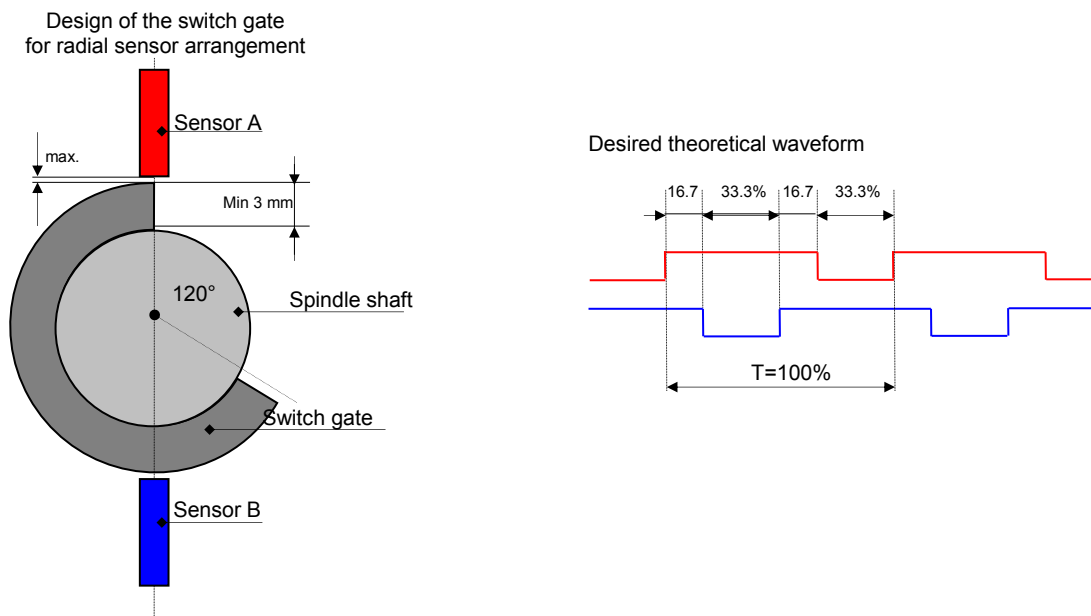

The diagnostics are to be designed for the following limits as a minimum:

Max. count frequency:	4 kHz
Min. count frequency:	1 Hz
Max. blanking 0 signal:	50%
Min. overlap:	10%

Reading the count signals:

The two count signals are each separately assigned to the two channels. The status is read synchronously in each of the two channels. To ensure synchronism, this action is to be undertaken immediately after channel synchronisation. The sampling must take place at least 1x per cycle. The max. deviation in the synchronism is 20 μ s.

The status conditions must be exchanged cross-wisely via the SPI.

Logic processing:

The following evaluation is to be undertaken in both channels:

Signal A	Signal B	Result
Low	Low	False
High	Low	True
Low	High	True
High	High	True

6 Response times of the PSC1

The response time is an important safety-related property and must be taken into account for each application / safety function. In the following section the response times for individual functions, in some case also as a function of other parameters, are listed. If this information is inadequate for a specific application, the actual response is to be validated against the required behaviour by means of specific measurements. This statement applies in particular also to the usage of filter functions.

Safety instructions:

- The response times are to be defined for each safety function in the required behaviour and compared against the actual value with the aid of the following information.
- Particular care is required on the usage of filter functions. Depending on the filter length / filter time, the response time may be significantly extended; this aspect must be taken into account in the safety-related design.
- In particularly critical tasks, the response is to be validated by means of measurements.
- On device startup / alarm or error reset, in some circumstances (depending on the application program) the outputs may become active for the duration of the response time. This aspect must be taken into account on planning the safety functions
- On the usage of safe fieldbus connections (e.g. PROFIsafe, FSoE) the system propagation time (watchdog) is to be included in the calculation.

6.1 Response times in standard operation

The basis for the calculation of response times is the cycle time of the PSC1. system. During operation this is **T_{cycle} = 8 ms**. The response times stated correspond to the related maximum propagation time within the PSC1 module for the specific application. Depending on the application, further application-dependent response times for the sensors and actuators used must be included in the calculation to obtain the total propagation time.

Function	Response time [ms]	Explanation
Activation of a monitoring function by means of ENABLE with subsequent shutdown via digital output	24 *)	Activation of a monitoring function by means of the ENABLE signal.
Activation of a monitoring function by means of ENABLE with subsequent shutdown via safety relay	47 *)	Activation of a monitoring function by means of the ENABLE signal.
Response of an already activated monitoring function including PLC processing for position and speed processing via digital output	16 *)	If a monitoring function is already activated via ENABLE, the module requires <u>one</u> cycle to calculate the actual speed value. In the next cycle, after the calculation of the monitoring function, the information is further processed and output by the PLC, i.e. based on the logic implemented this results, e.g., in the switching of an output.
Response of an already activated monitoring function including PLC processing for position and speed processing via safety relay	39 *)	If a monitoring function is already activated via ENABLE, the module requires <u>one</u> cycle to calculate the actual speed value. In the next cycle, after the calculation of the monitoring function, the information is further processed and output by the PLC, i.e. based on the logic implemented this results, e.g., in the switching of an output.
Activation of digital output via digital input	16	Activation of an input and switching the output
Activation of output relay via digital input	26	Activation of an input and switching the output
Deactivation of digital output via digital input	16	Deactivation of an input and therefore deactivation of the output
Deactivation of output relay via digital input	47	Deactivation of an input and therefore deactivation of the output
Mean value filter (for setting see encoder dialogue box SafePLC2)	0 - 64	Group propagation time for the averager. This propagation time only acts on monitoring functions related to position / speed / acceleration, however not on the logic processing.
Activation of digital output via 2 manual elements	32 ms	Activation of the 2 manual elements and therefore deactivation of the output
Deactivation of digital output via 2 manual elements	32 ms	Deactivation of the 2 manual elements and therefore deactivation of the output

Note:

*) On the usage of a mean value filter, its response time must be included

6.2 Response times for FAST_CHANNEL

FAST_CHANNEL refers to a property of the PSC1 to react faster to speed requirements than is possible on processing the safety program in the normal cycle (= 8 ms). The sampling time of the FAST_CHANNEL is 2 ms + 2 ms for signalling on bus.

The following response times can be stated:

- 4 ms (worst-case condition)

Safety instructions:

- On the usage of the FAST_CHANNEL it is to be noted that a shutdown in the time stated above for a specified speed threshold can only occur if the sensor information is of adequate resolution. The smallest resolvable switching threshold for the FAST_CHANNEL requires at least 2 edge changes on the selected sensor system within a time of 2 ms.
- This function is only possible on the usage of safe semiconductor outputs.
- The FAST_CHANNEL must not act on SSI listeners

6.3 Response times for overspeed distance monitoring

For the calculation of the worst-case condition, there is the following calculation scheme:

System speed at sampling point:	$V(t)$
System speed on response from the PSC1:	V_A
(tThreshold for monitoring (SLS or SCA) :	$V_S = \text{constant for all } t$
Filter value configured:	$XF = \text{constant for all } t$
Maximum possible acceleration for the application:	$a_F = \text{constant for all } t$
Delay after shutdown:	$a_V = \text{constant for all } t$
Sampling point for occurrence of worst-case event:	T_{Fault}
Response time of the PSC1 system:	t_{Resp}

For the worst-case assessment it is assumed that the drive is initially moving at a speed $v(k)$ exactly at the threshold configured v_0 and then accelerates with the maximum possible value a_0 .

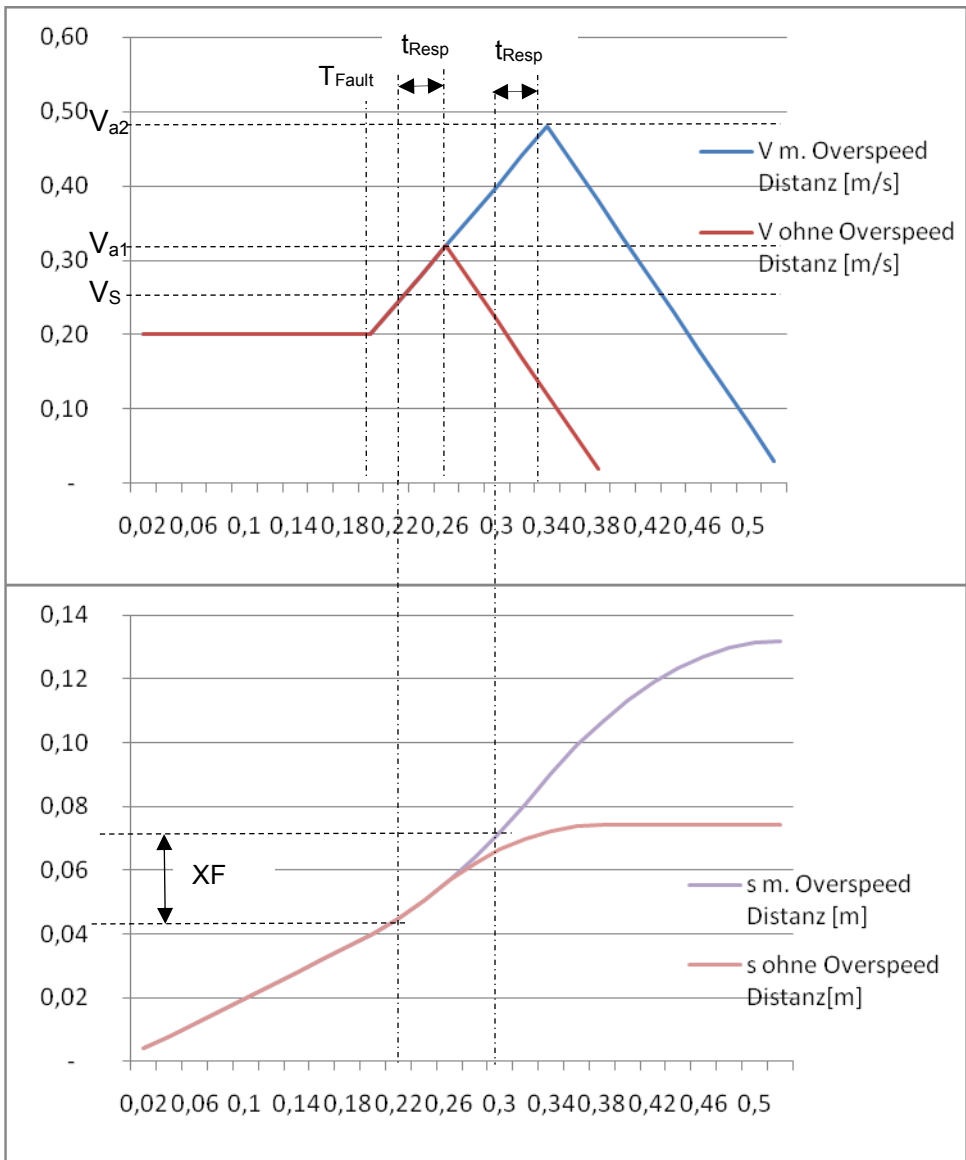

Behaviour of the drive with / without overspeed distance

For the V and s curves there are the following relationships without overspeed distance:

Parameter	Acceleration method	Remark
t_{Resp}	Value from PSC1 response time data + delay in external shutdown chain	Delay in external shutdown chain from relay / contactor, brake manufacturer data etc.
a_F, a_v	n.a.	Estimation from application
V_{a1}	$= V_s + a_F * t_{Resp}$	

For the V and s curves with overspeed distance the following applies:

Parameter	Acceleration method	Remark
t_{Resp}	Value from PSC1 response time data + delay in external shutdown chain	Delay in external shutdown chain from relay / contactor, brake manufacturer data etc.
a_F, a_V	n.a.	Estimation from application
V_{a2}	$= a_F * t_{Resp} + (V_S^2 + 2 * a_F * XF)^{1/2}$	

With its action the filter displaces upward the speed threshold set V_a by an amount **delta_v_filter**. For the application the new values for the response time ($T_{Resp} = T_{PSC1} + T_{Filter}$), as well as the resulting speed on shutdown by the PSC1 are to be taken into account.

6.4 Response times when using the PSC1-E-3x

The basis for the calculation of response times is the cycle time of the PSC1. system. During operation this is **$T_{cycle} = 8 \text{ ms}$** . The response times stated correspond to the related maximum propagation time within the PSC1 module for the specific application. Depending on the application, further application-dependent response times for the sensors and actuators used must be included in the calculation to obtain the total propagation time.

Function	Identifier	Response time [ms]	Explanation
Worst-case delay, input in the basic module to the PAE	T_{IN_BASE}	10	E.g. activation of a monitoring function by an input signal in the basic module
Worst-case delay, input PSC1-E-31 to the PAE in basic module	T_{IN_31}	18	E.g. activation of a monitoring function by an input signal in the expansion module PSC1-E-31
Processing time PAE to PAA in basic module	T_{PLC}	8	Shutdown by a monitoring function or by an input in the PAE
Activation / deactivation of digital output in basic module from PAA	T_{OUT_BASE}	-	Activation or deactivation of an output in the basic module after change in the PAA
Activation / deactivation of digital output in expansion module via PAA on basic module	T_{OUT_31}	8	Activation or deactivation of an output in the expansion module PSC1-E-31 after change in the PAA in the basic module

Determination of the total response time

$$T_{TOTAL} = T_{IN} + T_{PLC} + T_{OUT}$$

Example 1:

Input on expansion module, activation of SLS and processing in PLC, output on basic module

$$T_{TOTAL} = T_{IN_31} + T_{PLC} + T_{OUT_Base} = 18 \text{ ms} + 8 \text{ ms} + 0 \text{ ms} = 26 \text{ ms};$$

Example 2:

Input on basic module, activation of SLS and processing in PLC, output on expansion module

$$T_{TOTAL} = T_{IN_Base} + T_{PLC} + T_{OUT_31} = 10 \text{ ms} + 8 \text{ ms} + 8 \text{ ms} = 26 \text{ ms};$$

Example 3:

Input on expansion module, activation of SLS and processing in PLC, output on expansion module

$$T_{TOTAL} = T_{IN_31} + T_{PLC} + T_{OUT_31} = 18 \text{ ms} + 8 \text{ ms} + 8 \text{ ms} = 34 \text{ ms};$$

7 Commissioning

7.1 Procedure

Commissioning is only allowed to be undertaken by qualified personnel!
 Please follow the safety instructions during commissioning!

7.2 Sequences for switching on

Each time after restarting the module, if there are no errors, the following phases are run through and displayed on the seven-segment display on the front:

<i>7-segment display</i>	<i>Mode</i>	<i>Description</i>
"1"	STARTUP	Synchronisation between both processor systems and checking the configuration/firmware data
"2"	SENDCONFIG	Distribution of the configuration/firmware data and further checking of these data. Subsequent range calculation for the configuration data.
"3"	STARTUP BUS	If present, initialisation of a bus system
"4"	RUN	Normal operation of the system. All outputs are switched based on the actual state of the logic.
"5"	STOP	Parameter data and program data can be loaded externally in the stop mode.
"A"	ALARM	Alarm can be reset via digital input or reset button on the front.
"E"	ECS alarm ICS alarm ACS alarm	ECS alarm can be reset via digital inputs or reset button on the front.
"F"	Fault	Faults can only be reset via module ON/OFF.
":."	F-Bus Status	Slave F-Bus (PROFIsafe/FSoE): Off: F bus not used Slow flashing: F bus configured, no connection to the master Fast flashing: Connection to the master, F bus activation pending On: F bus connected

7.3 Reset behaviour

The reset function differentiates between a startup function after the return of the power supply = general reset and a status/alarm reset = "internal reset". The latter is triggered via the front button or an input configured accordingly = start/reset element with activated "alarm reset or logic reset" function. The following table provides an overview on the reset functions and their effect.

7.3.1 Reset types and triggering element

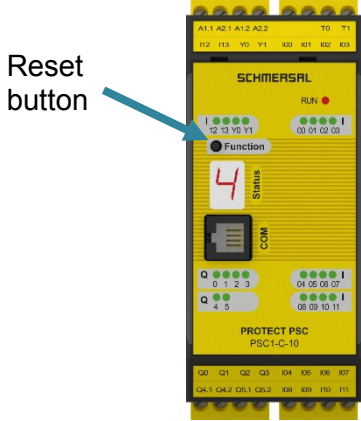
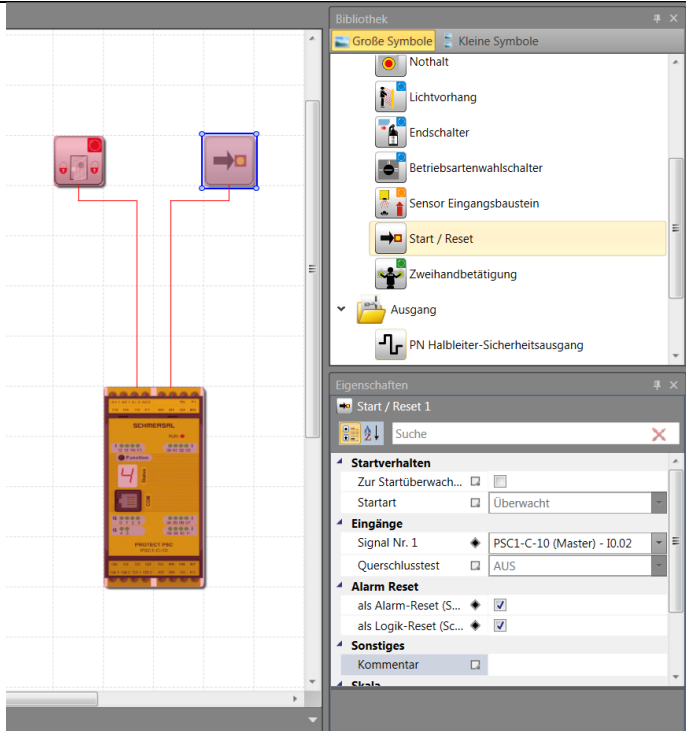
Reset type	Triggering element	Remark
General reset	Return of supply of power / device startup	Reset function after completely switching off and on the device
Internal reset		The internal reset is triggered using the Reset button on the front
		Configuration of a reset input

7.3.2 Reset timing

An "Internal Reset" is triggered with the falling edge of the reset input.

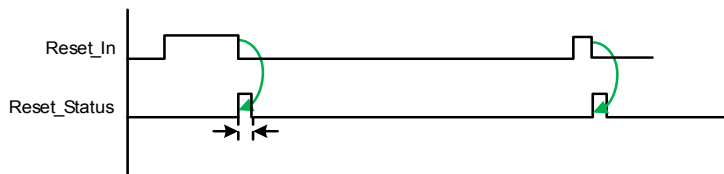

7.3.3 Reset function

Function unit	General Reset	Internal Reset	Function
Fatal error	X		Reset error
Alarm	X	X	Reset alarm
Monitoring functions	X	X	Resetting a triggered monitoring function
Flip-flop	X	X ⁽¹⁾	Status = Reset
Timer	X	X	Timer = 0

(1)

Attention:

As the start/reset element is configured here as a logic reset and connected as an element to a flip-flop element, the flip-flop is reset at high signal...

The status of the monitoring functions is formed again after a reset:

- If the limits configured are exceeded, process values do not cause the output status of the monitoring function to change
- Time-based functions - timers reset the output status of the monitoring function. Triggering only occurs if the limits configured are exceeded again

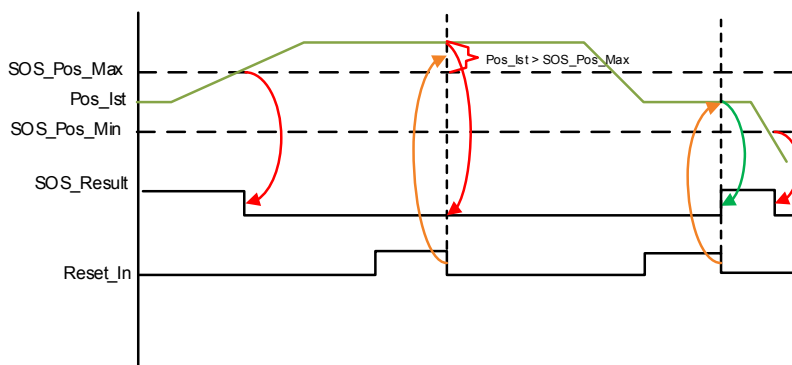

Process value (position) => no change to the output status on reset in the alarm state

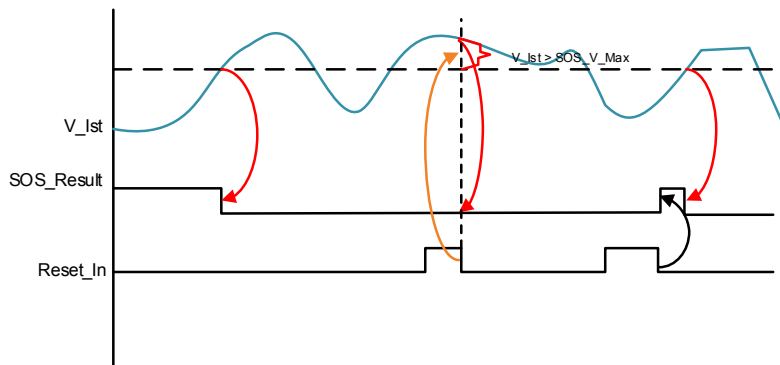

Process value (speed) => no change to the output status on reset in the alarm state

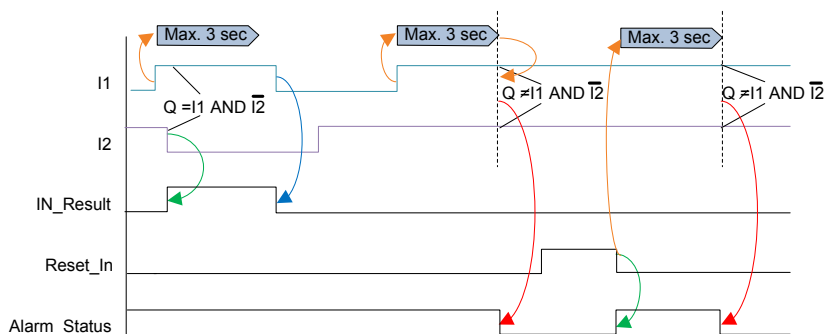

Time-based function => reset the output status, triggering if limit exceeded again

Safety instructions:

- For time-based functions, e.g. monitoring of the timing of complementary input signals, the output status is reset and a state defined as erroneous only detected if the (time) limit is exceeded again.
- To protect against incorrect usage, e.g. repeated triggering of the reset function to bypass an alarm state, if necessary applicative measures must be taken in the PLC programming.

7.3.3.1 Example reset function with protection against incorrect usage

Function:

- On a machine, the hazard area is to be protected in normal operation by a guard and in the setting up mode by an enable button in conjunction with standstill monitoring and safely limited speed.
- The presence of the guard is monitored by an electrical sensor. If the guard is open, movement is only possible with the enable button actuated.
- In the program this aspect is realised by a "Safety door" function (2-channel with time monitoring) and an "Enable" function.
- The "Safety door" logic signal is generated using input pre-processing with complementary inputs and time monitoring. The time monitoring for this element is fixed at 3 seconds.
- If the safety door is open ("LOW" signal), the axis can be moved at reduced speed if enabling is active.

Problem:

- If a "cross-circuit" fault is simulated on the safety door input, the PSC1 module indicates the alarm 6701.
- This alarm can be acknowledged and the "safety door" signal correctly remains at "0".
- After the time monitoring of 3 seconds has elapsed, alarm 6701 is triggered again.
- If the enable is pressed during this period, the axis can be moved again for 3 seconds.

Application-related measure:

Using an operator in the PLC program, the activation of the outputs while bypassing the alarm state for this time is prevented.

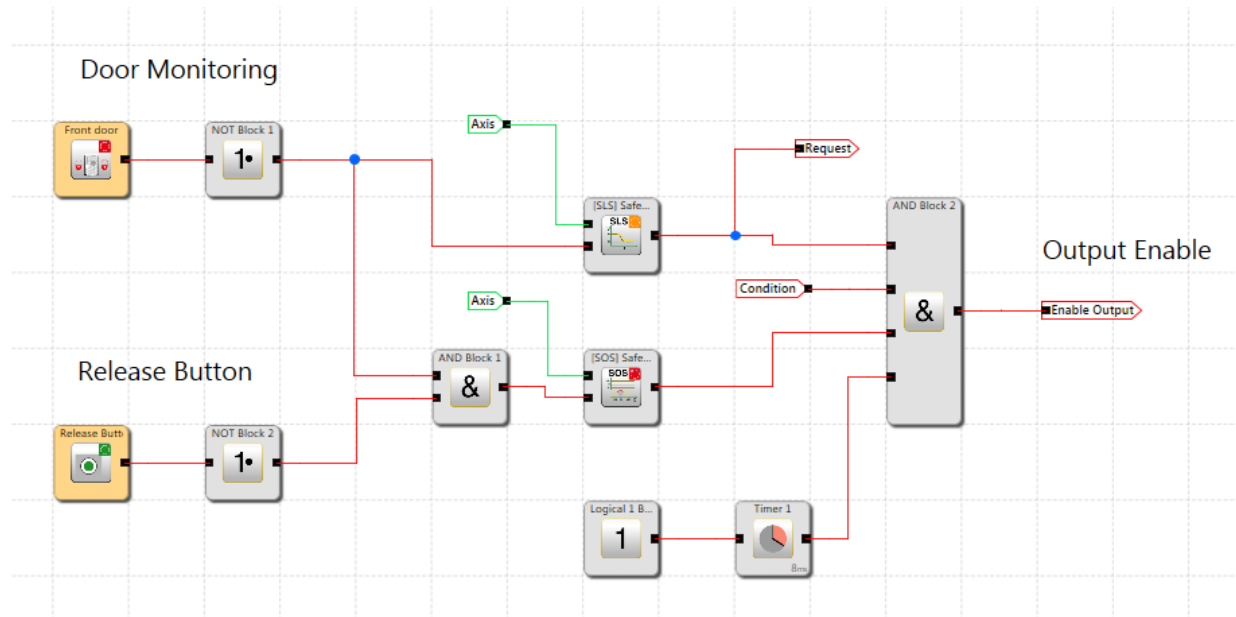

Example 1:

- The enable function for the outputs (AND function) is also linked to a "reset timer". This operator prevents the activation of the outputs for $t > 3$ sec after a reset => the renewed action of time monitoring is safeguarded.

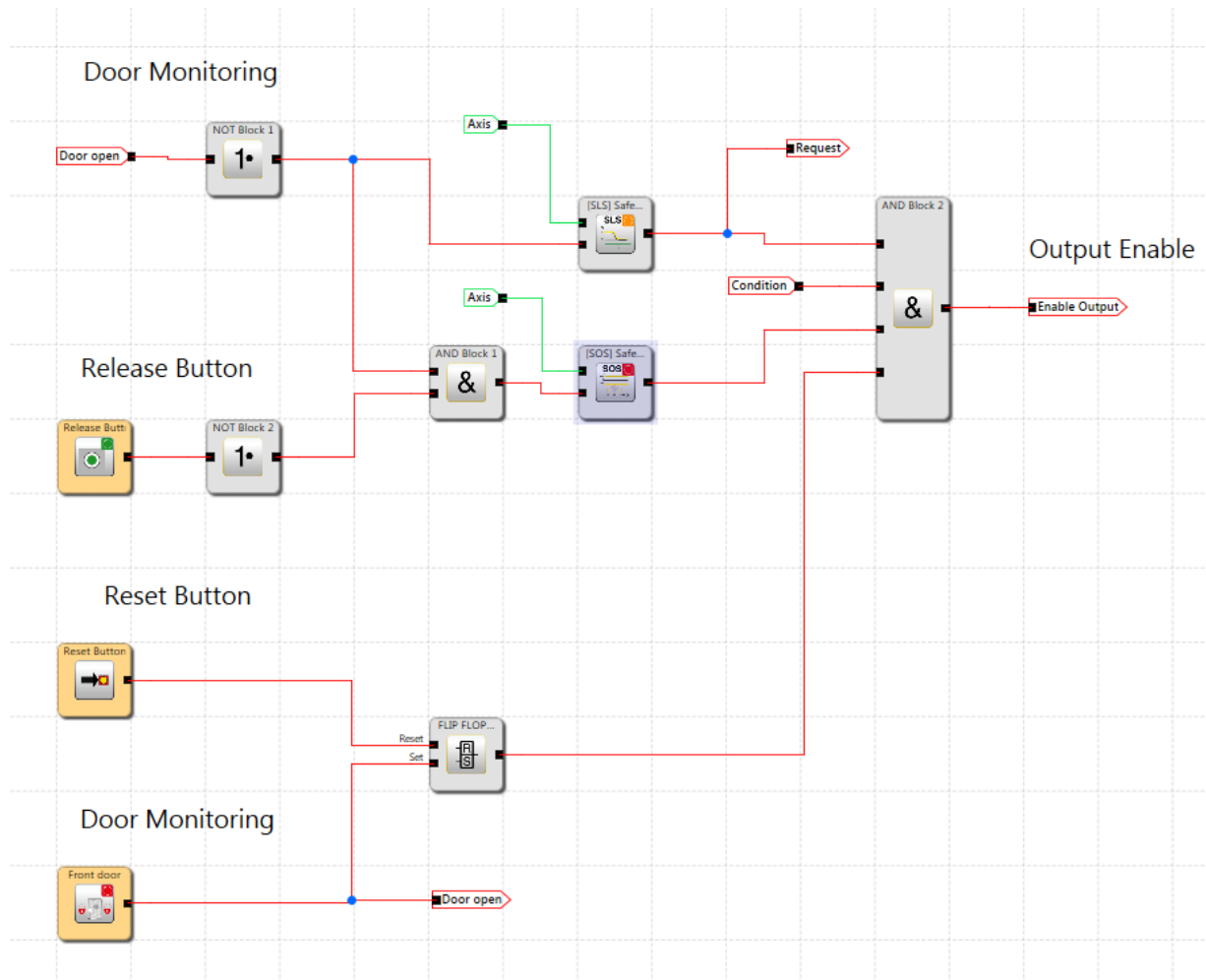

Example 2:

- The enable function for the outputs (AND function) is also linked to FF. This operator prevents the activation of the outputs after a reset if there is a fault present in the input circuit. The outputs are only enabled after an error-free input signal has been applied once.

7.4 LED indication

<i>Colour</i>	<i>Mode</i>	<i>Description</i>
Green	"Flashing"	System OK, configuration validated
Yellow	"Flashing"	System OK, configuration not yet validated
Red	"Flashing"	Alarm
Red	"Continuous"	Fatal error
Yellow - red	"Flashing"	System OK, configuration not validated, SMMC ⁽¹⁾ configured but no bus user
Green - red	"Flashing"	System OK, configuration validated, SMMC ⁽¹⁾ configured but no bus user

Options:

(1) on request

Note:

For all operating states except RUN, the outputs are rendered passive by the firmware, i.e. safely shut down. In the RUN state, the state of the outputs is dependent on the PLC program implemented.

7.5 Parameter configuration

The parameters are configured using the program SafePLC2. To be able to send the data to the module, a programming adapter is required; the user must install the driver for this adapter prior to use.

For a description of the parameter configuration, see *Programming manual*.

7.6 Function test

To safeguard the safety of the module, a function test on the safety functions must be undertaken once per year.

7.7 Validation

To safeguard the safety functions implemented, the parameters and operators must be checked and documented by the user after completion of commissioning and parameter configuration. Support for this task is provided by the validation wizard in the user interface (see section "Safety-related check").

8 Safety-related check

To safeguard the safety functions implemented, the parameters and operators must be checked and documented by the user after completion of commissioning and parameter configuration. Support for this task is provided by the parameter configuration software SafePLC2 (see Programming manual).

General information on the installation can be provided on the first two pages. On the pages of the validation report that follow, all functions used and their parameters are printed out as itemised evidence of the safety-related check.

After the transfer of the configuration and program data to the SPC1 module, the status LED flashes yellow. This indication indicates that the configuration data have not yet been validated.

When you click the "KONFIGURATION SPERREN" (LOCK CONFIGURATION) button at the end of the validation dialogue box, the data are marked as "validated" and the LED flashes "green".

9 Maintenance

9.1 Modification / dealing with changes to the device

Servicing work is only allowed to be undertaken by qualified personnel.
It is not necessary to undertake regular servicing work.

Repair

Devices are always to be replaced completely.
It is only possible to repair a device in the factory.

Warranty

The warranty will be rendered void if the module is opened without authorisation.

Note:

The modification of the module will render void the safety approval!

9.2 Replacement of a module

On the replacement of a module the following should be noted:

- Disconnect power converter from the main supply.
- Switch off power supply for the device and disconnect.
- Disconnect encoder connector
- Remove all other plug-in connections.
- Remove module from the DIN rail and correct correctly in relation to EMC.
- Fit new module to the DIN rail.
- Restore all connections.
- Switch on power converter.
- Switch on supply voltage.
- Configure device

Note:

In principle, no plug-in connection on the PSC1 module is allowed to be disconnected or connected again while electrically live. In particular, there is a risk of irreparable damage to position or speed sensors connected.

9.3 Servicing interval

Module replacement	See technical data
Function test	See section Commissioning

10 Technical data



10.1 Ambient conditions

Degree of protection	IP 20
Ambient temperature	0 °C* ... 50 °C
Climatic class	3k3 according to DIN 60 721
Service life (Tm, time to mission))	20 years in 50 °C environment

10.2 Safety-related characteristic data

Max. achievable safety class	<ul style="list-style-type: none"> • SIL 3 as per EN61508 • Category 4 as per EN945-1 • Performance Level e as per EN ISO 13849-1 	
System structure	2-channel with diagnostics (1002) according to EN 61508 Architecture category 4 according to EN ISO 13849	
Design of the operating mode	"High demand" as per EN 61508	
Probability of a dangerous failure per hour (PFH value)	PSC1-C-10-x	see section 3.7.1
	PSC1-E-3x	see section 3.7.2
Specific values as per tables "Safety-related characteristic data"		
Proof test interval (IEC 61508)	20 years, after that the module must be replaced	

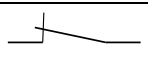
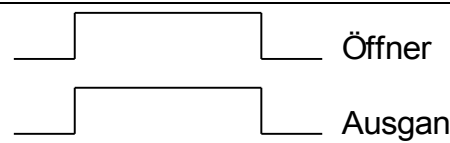
11 Switch types

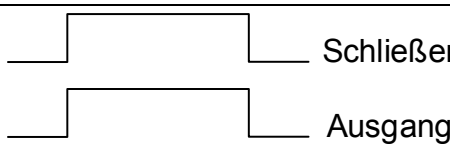
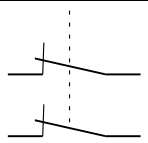
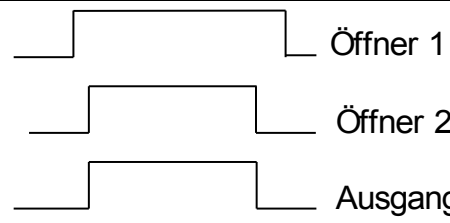
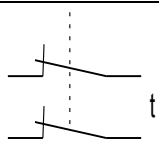
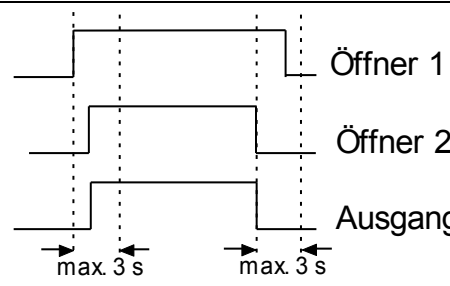
Typ e	Switch symbol	Truth table	Function block	Function																
1	 eSwitch_1o	<table border="1"> <thead> <tr> <th>NC</th> <th>A</th> </tr> </thead> <tbody> <tr> <td>0</td> <td>0</td> </tr> <tr> <td>1</td> <td>1</td> </tr> </tbody> </table>	NC	A	0	0	1	1		Truth table behaves like an normally open contact, only the symbol is a normally closed contact										
NC	A																			
0	0																			
1	1																			
2	 sSwitch_1s	<table border="1"> <thead> <tr> <th>S</th> <th>A</th> </tr> </thead> <tbody> <tr> <td>0</td> <td>0</td> </tr> <tr> <td>1</td> <td>1</td> </tr> </tbody> </table>	S	A	0	0	1	1		Normally open contact, like type 1										
S	A																			
0	0																			
1	1																			
3	 eSwitch_2o	<table border="1"> <thead> <tr> <th>NC1</th> <th>NC2</th> <th>A</th> </tr> </thead> <tbody> <tr> <td>0</td> <td>0</td> <td>0</td> </tr> <tr> <td>1</td> <td>0</td> <td>0</td> </tr> <tr> <td>0</td> <td>1</td> <td>0</td> </tr> <tr> <td>1</td> <td>1</td> <td>1</td> </tr> </tbody> </table>	NC1	NC2	A	0	0	0	1	0	0	0	1	0	1	1	1		AND operation both inputs	
NC1	NC2	A																		
0	0	0																		
1	0	0																		
0	1	0																		
1	1	1																		
4	 eSwitch_2oT	<table border="1"> <thead> <tr> <th>NC1</th> <th>NC2</th> <th>A</th> </tr> </thead> <tbody> <tr> <td>0</td> <td>0</td> <td>0</td> </tr> <tr> <td>1</td> <td>0</td> <td>0</td> </tr> <tr> <td>0</td> <td>1</td> <td>0</td> </tr> <tr> <td>1</td> <td>1</td> <td>1</td> </tr> </tbody> </table>	NC1	NC2	A	0	0	0	1	0	0	0	1	0	1	1	1	Time monitoring	Like 3, however with time monitoring of state changes. On signal change on one of the NC, complementary signal must follow within time $t=3$ s. If not change to fault and $O=0$	
NC1	NC2	A																		
0	0	0																		
1	0	0																		
0	1	0																		
1	1	1																		

Installation manual

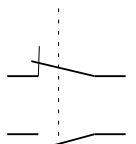
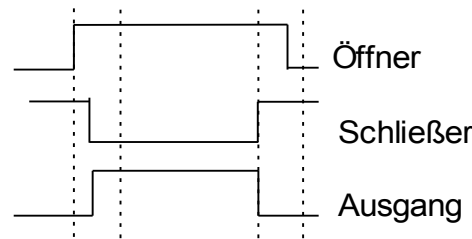
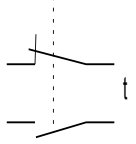
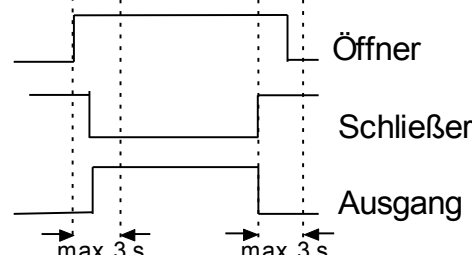
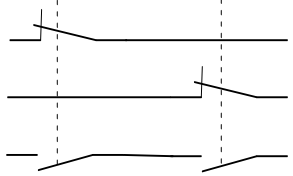
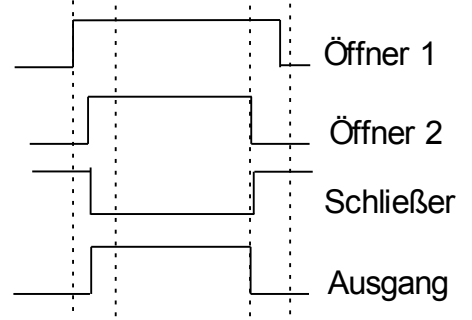
Typ e	Switch symbol	Truth table		Function																										
5	 eSwitch_1s1o	<table border="1"> <thead> <tr> <th>S</th> <th>NC</th> <th>A</th> </tr> </thead> <tbody> <tr> <td>0</td> <td>0</td> <td>0</td> </tr> <tr> <td>1</td> <td>0</td> <td>0</td> </tr> <tr> <td>0</td> <td>1</td> <td>1</td> </tr> <tr> <td>1</td> <td>1</td> <td>0</td> </tr> </tbody> </table>	S	NC	A	0	0	0	1	0	0	0	1	1	1	1	0		Monitoring for NO = inactive and NC = active											
S	NC	A																												
0	0	0																												
1	0	0																												
0	1	1																												
1	1	0																												
6	 eSwitch_1s1oT	<table border="1"> <thead> <tr> <th>S</th> <th>NC</th> <th>A</th> </tr> </thead> <tbody> <tr> <td>0</td> <td>0</td> <td>0</td> </tr> <tr> <td>1</td> <td>0</td> <td>0</td> </tr> <tr> <td>0</td> <td>1</td> <td>1</td> </tr> <tr> <td>1</td> <td>1</td> <td>0</td> </tr> </tbody> </table>	S	NC	A	0	0	0	1	0	0	0	1	1	1	1	0	Time monitoring	Like 5, however with time monitoring of state changes. On signal change on one of the NC, complementary signal must follow within time $t=3$ s. If not change to fault and O=0											
S	NC	A																												
0	0	0																												
1	0	0																												
0	1	1																												
1	1	0																												
7	 eSwitch_2s2o	<table border="1"> <thead> <tr> <th>N O1</th> <th>N C 1</th> <th>N O 2</th> <th>N C 2</th> <th>A</th> </tr> </thead> <tbody> <tr> <td>1</td> <td>0</td> <td>1</td> <td>0</td> <td>0</td> </tr> <tr> <td>0</td> <td>1</td> <td>1</td> <td>0</td> <td>0</td> </tr> <tr> <td>0</td> <td>1</td> <td>0</td> <td>1</td> <td>1</td> </tr> <tr> <td>1</td> <td>0</td> <td>0</td> <td>1</td> <td>0</td> </tr> </tbody> </table>	N O1	N C 1	N O 2	N C 2	A	1	0	1	0	0	0	1	1	0	0	0	1	0	1	1	1	0	0	1	0		Monitoring for NO1*NO2= inactive and NC1*NC2= active	
N O1	N C 1	N O 2	N C 2	A																										
1	0	1	0	0																										
0	1	1	0	0																										
0	1	0	1	1																										
1	0	0	1	0																										

Installation manual

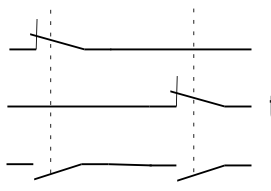
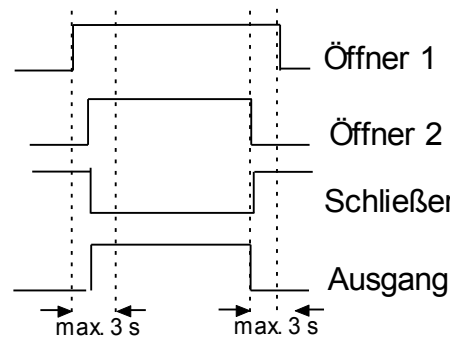
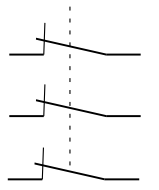
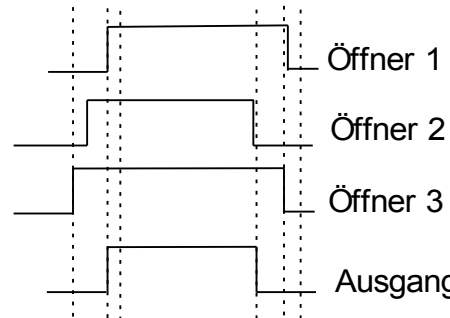
Typ e	Switch symbol	Truth table		Function																										
8	 <p>eSwitch_2s2oT</p>	<table border="1"> <thead> <tr> <th>N O1</th> <th>N C 1</th> <th>NO 2</th> <th>NC 2</th> <th>A</th> </tr> </thead> <tbody> <tr> <td>1</td> <td>0</td> <td>1</td> <td>0</td> <td>0</td> </tr> <tr> <td>0</td> <td>1</td> <td>1</td> <td>0</td> <td>0</td> </tr> <tr> <td>0</td> <td>1</td> <td>0</td> <td>1</td> <td>1</td> </tr> <tr> <td>1</td> <td>0</td> <td>0</td> <td>1</td> <td>0</td> </tr> </tbody> </table>	N O1	N C 1	NO 2	NC 2	A	1	0	1	0	0	0	1	1	0	0	0	1	0	1	1	1	0	0	1	0	Time monitoring	Like 7, however with time monitoring of state changes. On signal change on NO (attention common wire!) or NC, complementary signal must follow within time $t=3$ s. If not change to fault and O=0	
N O1	N C 1	NO 2	NC 2	A																										
1	0	1	0	0																										
0	1	1	0	0																										
0	1	0	1	1																										
1	0	0	1	0																										
9	 <p>eSwitch_3o</p>	<table border="1"> <thead> <tr> <th>NC1</th> <th>NC2</th> <th>NC 3</th> <th>A</th> </tr> </thead> <tbody> <tr> <td>0</td> <td>0</td> <td>0</td> <td>0</td> </tr> <tr> <td>1</td> <td>0</td> <td>0</td> <td>0</td> </tr> <tr> <td>0</td> <td>1</td> <td>0</td> <td>0</td> </tr> <tr> <td>1</td> <td>1</td> <td>0</td> <td>0</td> </tr> <tr> <td>1</td> <td>1</td> <td>1</td> <td>1</td> </tr> </tbody> </table>	NC1	NC2	NC 3	A	0	0	0	0	1	0	0	0	0	1	0	0	1	1	0	0	1	1	1	1		AND operator on the three inputs		
NC1	NC2	NC 3	A																											
0	0	0	0																											
1	0	0	0																											
0	1	0	0																											
1	1	0	0																											
1	1	1	1																											

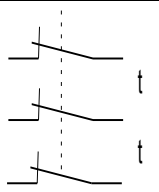
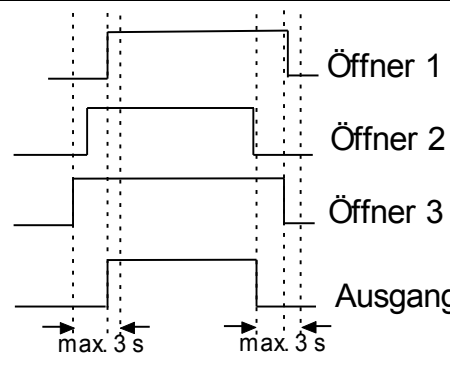
10	 eSwitch_3oT	NC1	NC2	NC 3	A	Time monitoring	Like 8, however with time monitoring of state changes. On signal change on one of the NC inputs the other inputs must follow within time $t=3$ s. If not change to fault and O=0	
		0	0	0	0			
		1	0	0	0			
		0	1	0	0			
		1	1	0	0			
1	1	1	1					

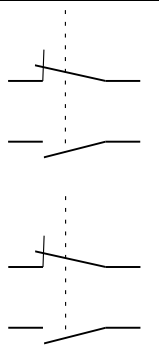
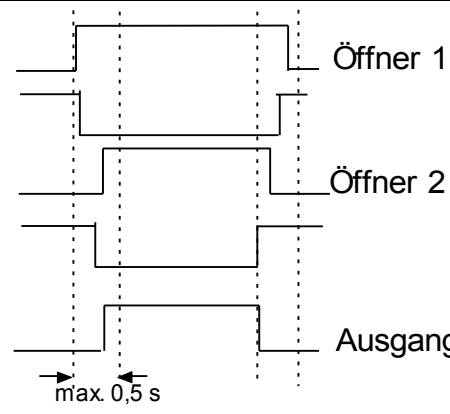
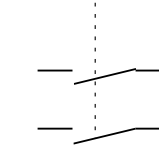
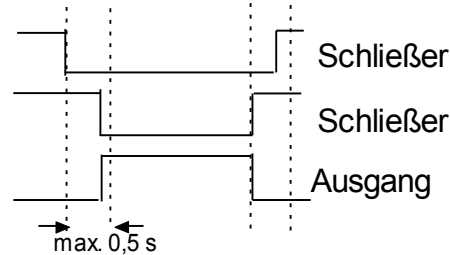
Typ e	Switch symbol	Truth table		Function																																				
11	 eTwoHand_2o	<table border="1"> <thead> <tr> <th>N</th> <th>N</th> <th>N</th> <th>N</th> <th>A</th> </tr> <tr> <th>C</th> <th>O</th> <th>C</th> <th>O</th> <th></th> </tr> </thead> <tbody> <tr> <td>1</td> <td>1</td> <td>2</td> <td>2</td> <td></td> </tr> <tr> <td>0</td> <td>1</td> <td>0</td> <td>1</td> <td>0</td> </tr> <tr> <td>1</td> <td>0</td> <td>0</td> <td>1</td> <td>0</td> </tr> <tr> <td>1</td> <td>0</td> <td>1</td> <td>0</td> <td>0</td> </tr> <tr> <td>0</td> <td>1</td> <td>0</td> <td>1</td> <td>1</td> </tr> </tbody> </table>	N	N	N	N	A	C	O	C	O		1	1	2	2		0	1	0	1	0	1	0	0	1	0	1	0	1	0	0	0	1	0	1	1	Two-hand control MEZ	Monitoring for $NO1*NO2 =$ inactive and $NC1*NC2 =$ active + time monitoring <u>of this state</u> . I.e. if there is a signal change on an NO from 1->0 or NC from 0->1 then the other signals (i.e. further $NO=0$ or $NC=1$) must follow within 0.5 s. If not the output remains = 0. No malfunction evaluation! No time monitoring on change to inactive state.	
N	N	N	N	A																																				
C	O	C	O																																					
1	1	2	2																																					
0	1	0	1	0																																				
1	0	0	1	0																																				
1	0	1	0	0																																				
0	1	0	1	1																																				
12	 eTwoHand_2s	<table border="1"> <thead> <tr> <th>N</th> <th>N</th> <th>A</th> </tr> <tr> <th>O</th> <th>O</th> <th></th> </tr> </thead> <tbody> <tr> <td>1</td> <td>2</td> <td></td> </tr> <tr> <td>1</td> <td>0</td> <td>0</td> </tr> <tr> <td>0</td> <td>1</td> <td>0</td> </tr> <tr> <td>0</td> <td>0</td> <td>0</td> </tr> <tr> <td>1</td> <td>1</td> <td>1</td> </tr> </tbody> </table>	N	N	A	O	O		1	2		1	0	0	0	1	0	0	0	0	1	1	1	Two-hand control MEZ	Monitoring for $NO1*NO2 =$ inactive + time monitoring <u>of this state</u> . I.e. if there is a signal change on an NO from 1->0 then the other signal (i.e. further $NO=0$) must follow within 0.5 s. If not the output remains = 0. No malfunction evaluation! No time monitoring on change to inactive state.															
N	N	A																																						
O	O																																							
1	2																																							
1	0	0																																						
0	1	0																																						
0	0	0																																						
1	1	1																																						

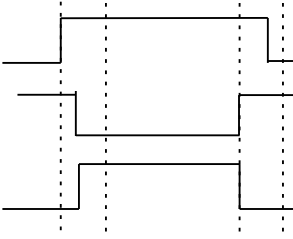
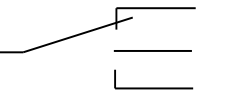
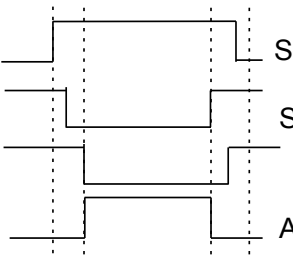
13	 eMode_1s1o	<table border="1"> <tr> <td>N</td> <td>N</td> <td>O</td> <td>O</td> </tr> <tr> <td>O</td> <td>O</td> <td>1</td> <td>2</td> </tr> <tr> <td>1</td> <td>2</td> <td></td> <td></td> </tr> <tr> <td>1</td> <td>0</td> <td>1</td> <td>0</td> </tr> <tr> <td>0</td> <td>1</td> <td>0</td> <td>1</td> </tr> <tr> <td>0</td> <td>0</td> <td>0</td> <td>0</td> </tr> <tr> <td>1</td> <td>1</td> <td>0</td> <td>0</td> </tr> </table>	N	N	O	O	O	O	1	2	1	2			1	0	1	0	0	1	0	1	0	0	0	0	1	1	0	0	Selector switch	Unambiguous operator for the permissible switch positions	 <p>Öffner Schließer Ausgang</p>																																						
N	N	O	O																																																																				
O	O	1	2																																																																				
1	2																																																																						
1	0	1	0																																																																				
0	1	0	1																																																																				
0	0	0	0																																																																				
1	1	0	0																																																																				
14	 eMode_3switch	<table border="1"> <tr> <td>N</td> <td>N</td> <td>S3</td> <td>O</td> <td>O</td> <td>O</td> </tr> <tr> <td>O</td> <td>O</td> <td></td> <td>1</td> <td>2</td> <td>3</td> </tr> <tr> <td>1</td> <td>2</td> <td></td> <td></td> <td></td> <td></td> </tr> <tr> <td>1</td> <td>0</td> <td>0</td> <td>1</td> <td>0</td> <td>0</td> </tr> <tr> <td>0</td> <td>1</td> <td>0</td> <td>0</td> <td>1</td> <td>0</td> </tr> <tr> <td>0</td> <td>0</td> <td>1</td> <td>0</td> <td>0</td> <td>1</td> </tr> <tr> <td>1</td> <td>1</td> <td>0</td> <td>0</td> <td>0</td> <td>0</td> </tr> <tr> <td>1</td> <td>0</td> <td>1</td> <td>0</td> <td>0</td> <td>0</td> </tr> <tr> <td>0</td> <td>1</td> <td>1</td> <td>0</td> <td>0</td> <td>0</td> </tr> <tr> <td>1</td> <td>1</td> <td>1</td> <td>0</td> <td>0</td> <td>0</td> </tr> <tr> <td>0</td> <td>0</td> <td>0</td> <td>0</td> <td>0</td> <td>0</td> </tr> </table>	N	N	S3	O	O	O	O	O		1	2	3	1	2					1	0	0	1	0	0	0	1	0	0	1	0	0	0	1	0	0	1	1	1	0	0	0	0	1	0	1	0	0	0	0	1	1	0	0	0	1	1	1	0	0	0	0	0	0	0	0	0	Selector switch	Unambiguous operator for the permissible switch positions	 <p>Schalter 1 Schalter 2 Schalter 3 Ausgang 1</p>
N	N	S3	O	O	O																																																																		
O	O		1	2	3																																																																		
1	2																																																																						
1	0	0	1	0	0																																																																		
0	1	0	0	1	0																																																																		
0	0	1	0	0	1																																																																		
1	1	0	0	0	0																																																																		
1	0	1	0	0	0																																																																		
0	1	1	0	0	0																																																																		
1	1	1	0	0	0																																																																		
0	0	0	0	0	0																																																																		

12 Notes for designing, programming, validating and testing safety-related applications

The following notes describe the procedures for designing, programming, validating and testing safety-related applications

The notes are intended to assist the user in arranging, clearly understanding and applying all steps from the risk assessment to the system test. For improved understanding of the related points, the individual steps are explained in more detail based on examples.

12.1 Risk assessment

In principle the manufacturer of a machine must ensure the machine designed and supplied is safe. The related applicable directives and standards are to be used for the assessment. The goal of the safety assessment and the resulting measures derived must be the reduction of the hazard for persons to an acceptable level.

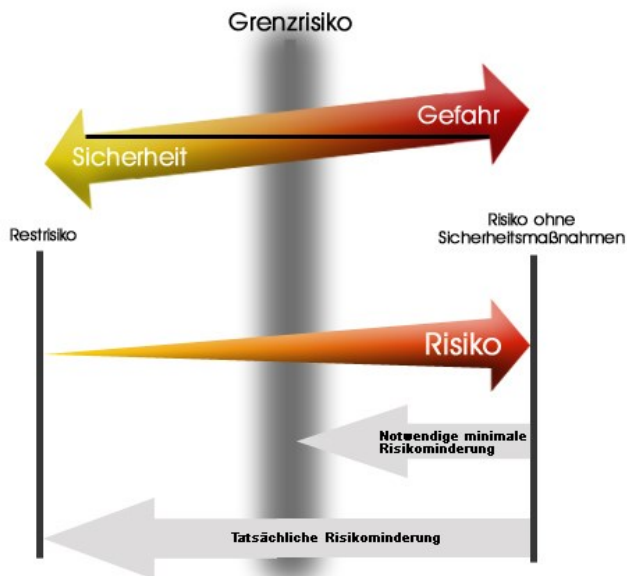

The analysis of the hazards must take into account all operating states of the machine such as operation, setting up and servicing or installing and decommissioning, as well all foreseeable misuse.

The necessary procedure for the risk assessment and the measures for the reduction of the risk are given, e.g., in the applicable standards

EN ISO 13849-1 Safety of machinery

EN ISO 61508 Functional safety of electrical/electronic/programmable electronic safety-related systems.

Risk assessment according to EN ISO 13849-1

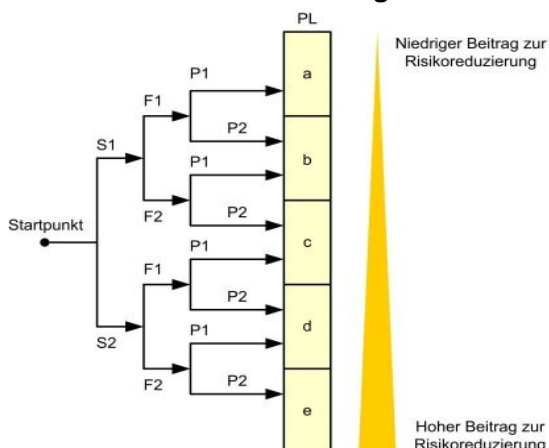

S – severity of injury
 S1 = slight, reversible injury
 S2 = serious, irreversible injury

F – frequency and/or exposure to hazard
 F1 = seldom, not cyclic
 F2 = frequent to continuous and/or exposure time is long, cyclic operation

P – possibility of avoiding hazard
 P1 = possible, slow movement / acceleration
 P2 = scarcely possible, high acceleration in event of a fault

Risk assessment according to EN ISO 61508

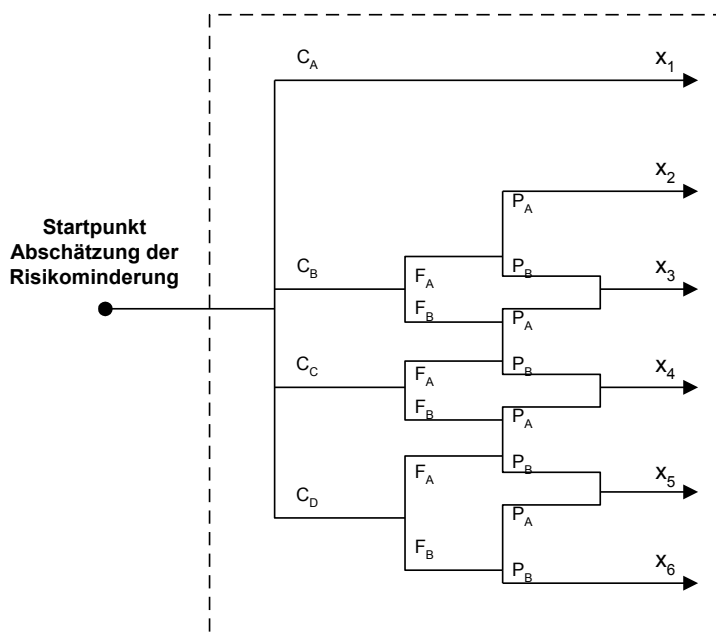

	W ₃	W ₂	W ₁
a	a	---	---
1	1	a	---
2	2	1	a
3	3	2	1
4	4	3	2
b	b	4	3

--- = keine Sicherheitsanforderung
 a = Keine speziellen Sicherheitsanforderungen
 b = eine einzelnes E/E/PES ist nicht ausreichend
 1,2,3,4 = Sicherheits-Integritätslevel

C = Risikoparameter der Auswirkung
 F = Risikoparameter der Häufigkeit und Aufenthaltsdauer
 P = Risikoparameter der Möglichkeit, den gefährlichen Vorfall zu vermeiden
 W = Wahrscheinlichkeit des unerwünschten Ereignisses

The risks to be considered are also given in the applicable directives and standards and are to be considered specifically by the manufacturer based on the manufacturer's specific knowledge of the machine.

For machines placed on the market in the EU, the risks to be considered as a minimum are specified in the EU Machinery directive 2006/42/EC or in the latest version of this directive.

Further information on the risk assessment and the safe design of machines is given in the standards

EN 14121 Safety of machinery - Risk assessment

EN 12100 Safety of machinery - General principles for design.

Measures that are applied to reduce the hazards identified must correspond as a minimum to the same level as the hazard. Such measures and the requirements on them are also given in examples in the directives and standards listed above.

12.2 Technical documentation required

Various technical documents are to be delivered by the manufacturer. The minimum scope of these documents is also given in the applicable directives and standards.

E.g. as per the EU Machinery directive the following documents as a minimum are to be delivered:

1. Die technischen Unterlagen umfassen:

a) eine technische Dokumentation mit folgenden Angaben bzw. Unterlagen:

- eine allgemeine Beschreibung der Maschine
- eine Übersichtszeichnung der Maschine und die Schaltpläne der Steuerkreise sowie Beschreibungen und Erläuterungen, die zum Verständnis der Funktionsweise der Maschine erforderlich sind
- vollständige Detailzeichnungen, eventuell mit Berechnungen, Versuchsergebnissen, Bescheinigungen usw., die für die Überprüfung der Übereinstimmung der Maschine mit den grundlegenden Sicherheits- und Gesundheitsschutzanforderungen erforderlich sind
- die Unterlagen über die Risikobeurteilung, aus denen hervorgeht, welches Verfahren angewandt wurde; dies schließt ein:
 - i) eine Liste der grundlegenden Sicherheits- und Gesundheitsschutzanforderungen, die für die Maschine gelten
 - ii) eine Beschreibung der zur Abwendung ermittelter Gefährdungen oder zur Risikominderung ergriffenen Schutzmaßnahmen und gegebenenfalls eine Angabe der von der Maschine ausgehenden Restrisiken
- die angewandten Normen und sonstige technische Spezifikationen unter Angabe der von diesen Normen erfassten grundlegenden Sicherheits- und Gesundheitsschutzanforderungen
- alle technischen Berichte mit den Ergebnissen der Prüfungen, die vom Hersteller selbst oder von einer Stelle nach Wahl des Herstellers oder seines Bevollmächtigten durchgeführt wurden
- ein Exemplar der Betriebsanleitung der Maschine
- gegebenenfalls die Einbauerklärung für unvollständige Maschinen und die Montageanleitung für solche unvollständigen Maschinen
- gegebenenfalls eine Kopie der EG-Konformitätserklärung für in die Maschine eingebaute andere Maschinen oder Produkte,
- eine Kopie der EG-Konformitätserklärung

b) bei Serienfertigung eine Aufstellung der intern getroffenen Maßnahmen zur Gewährleistung der Übereinstimmung aller gefertigten Maschinen mit den Bestimmungen dieser Richtlinie

Source BGIA Report 2/2008

The documents must be prepared such that they are easy to understand and in the national language.

12.3 Steps required for designing, realisation and testing

The realisation of parts of systems with a safety-related function requires particular care during planning, realisation and testing. Guidelines on these issues are also given in the applicable standards (cf. EN ISO 13849-2 or EN ISO 61508). The effort here depends on the complexity of the task for parts of the system with a safety-related function.

For the realisation of such functions with the aid of safety-related control and monitoring functions, the PSC1 series offers efficient support in the form of the system architecture (architecture cat. 4 according to EN ISO 13849-1) and above all also the programming language and tested safety functions. Programming is in the form of FUP (function plan-orientated programming) as recommended in the safety standards. It also corresponds to the requirements on a limited variability programming language (LVL) for which significant simplifications in the documentation and test scope apply.

In any case the individual steps require careful planning and analysis of the methods and systems used. The individual steps are also to be documented so they are clearly traceable.

V model (simplified):

The implementation of safety-related functions requires a structured procedure as is shown, for example, in the V model recommended in applicable standards. In the following as an example the procedure for applications with modules from the PSC1 series is shown.

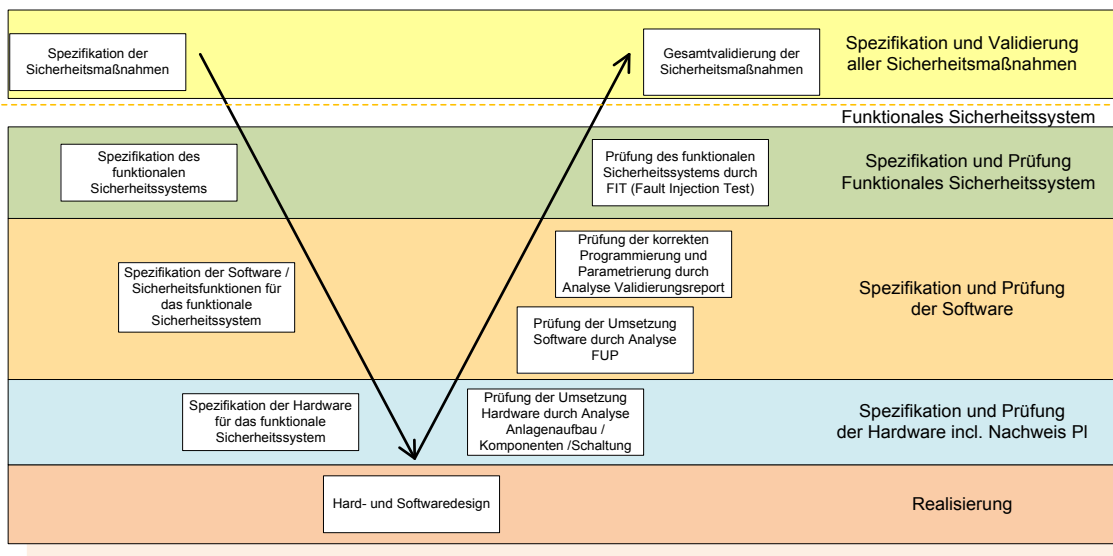

12.3.1 Phases of the V model

Designation	Description	
	Design phase	Validation phase
Specification and validation of all passive and active safety measures	Specification of all safety measures to be taken such as covers, barriers, max. machine parameters, safety-related functions etc.	Check on all passive and active safety measures for their correct implementation and effectiveness
Specification of the functional safety system	Specification of the active safety systems and their allocation to the risks to be reduced, e.g. limited speed in setting up mode, stop mode, monitoring of the access areas etc. Specification of the PLr or required SIL for each individual safety function	Check on all active safety systems for their effectiveness and compliance with the parameters specified, e.g. incorrectly increased speed, incorrect stop, triggering of monitoring devices etc. using practical tests
Specification of the software / safety functions	Specification of the functionality of individual safety functions incl. definition of the shutdown circuit etc. Definition of the parameters for the individual safety function, e.g. max. speed, stop ramps and category etc.	Check on the correct implementation of the functional specifications by means of analysis of FUP programming Validation of the application program and the parameters by comparison of the validation report with FUP and specifications for parameters
Specification of the hardware	Specification of the system layout and the functions for the individual sensors, controls, control components and actuators in relation to the safety functions	Check on the correct implementation of the specifications. Determination of the probability of failure or PL by means of analysis of the complete architecture and the characteristic data for all components involved, in each case in relation to the individual safety functions
Hardware and software design	Specific planning and implementation of the system layout / wiring. Specific implementation of the safety functions by means of programming in FUP	

12.3.2 Specification of the safety requirements (breakdown)

The safety requirements are to be analysed in detail based on the standards to be applied, e.g. product standards.

1	Allgemeine Produkt- und Projektangaben
1.1	Produktidentifikation
1.2	Autor, Version, Datum, Dokumentenname, Dateiname
1.3	Inhaltsverzeichnis
1.4	Begriffe, Definitionen, Glossar
1.5	Versionshistorie und Änderungsvermerke
1.6	Für die Entwicklung relevante Richtlinien, Normen und technische Regeln
2	Funktionale Angaben zur Maschine, soweit sicherheitstechnisch von Bedeutung
2.1	Bestimmungsgemäße Verwendung und vernünftigerweise vorhersehbare Fehlanwendung/-bedienung
2.2	Prozessbeschreibung (Betriebsfunktionen)
2.3	Betriebsarten (z. B. Einrichtbetrieb, Automatikbetrieb, Betrieb mit lokalem Bezug odervon Teilen der Maschine)
2.4	Kennndaten, z. B. Zykluszeiten, Reaktionszeiten, Nachlaufwege
2.5	Sonstige Eigenschaften der Maschine
2.6	Sicherer Zustand der Maschine
2.7	Wechselwirkung zwischen Prozessen (siehe auch 2.2) und manuellen Aktionen (Reparatur, Einrichten, Reinigen, Fehlersuche usw.)
2.8	Handlungen im Notfall
3	Erforderliche(r) Performance Level (PL _r)
3.1	Referenz auf vorhandene Dokumentation zur Gefährdungsanalyse und Risikobeurteilung der Maschine
3.2	Ergebnisse der Risikobeurteilung für jede ermittelte Gefährdung oder Gefährdungssituation und Festlegung der zur Risikominderung jeweils erforderlichen Sicherheitsfunktion(en)
4	Sicherheitsfunktionen (Angaben gelten für jede Sicherheitsfunktion)
	- Funktionsbeschreibung („Erfassen – Verarbeiten – Ausgeben“) einschließlich aller funktionaler Eigenschaften (siehe auch Tabellen 5.1 und 5.2)
	- Aktivierungs-/Deaktivierungsbedingungen oder -ereignisse (z. B. Betriebsarten der Maschine)
	- Verhalten der Maschine beim Auslösen der Sicherheitsfunktion
	- zu berücksichtigende Wiederanlaufbedingungen
	- Leistungskriterien/Leistungsdaten
	- Ablauf (zeitliches Verhalten) der Sicherheitsfunktion mit Reaktionszeit
	- Häufigkeit der Betätigung (d. h. Anforderungsrate), Erholungszeiten nach Anforderung
	- sonstige Daten
	- einstellbare Parameter (soweit vorgesehen)
	- Einordnung und Zuordnung von Prioritäten bei gleichzeitiger Anforderung und Bearbeitung mehrerer Sicherheitsfunktionen
	- funktionales Konzept zur Trennung bzw. Unabhängigkeit/Rückwirkungsfreiheit zu Nicht-Sicherheitsfunktionen und weiteren Sicherheitsfunktionen
5	Vorgaben für den SRP/CS-Entwurf
5.1	Zuweisung, durch welche SRP/CS und in welcher Technologie die Sicherheitsfunktion realisiert werden soll, vorgesehene Betriebsmittel
5.2	Auswahl der Kategorie, vorgesehene Architektur (Struktur) als sicherheitsbezogenes Blockdiagramm mit Beschreibung
5.3	Schnittstellenbeschreibung (Prozessschnittstellen, interne Schnittstellen, Bedienerchnittstellen, Bedien- und Anzeigeelemente usw.)
5.4	Einschaltverhalten, Umsetzung des erforderlichen Anlaufverhaltens und Wiederanlaufverhaltens
5.5	Leistungsdaten: Zykluszeiten, Reaktionszeiten usw.
5.6	Verhalten des SRP/CS bei Bauteilausfällen und -fehlern (Erreichen und Aufrechterhalten des sicheren Zustandes) einschließlich Zeitverhalten
5.7	Zu berücksichtigende Ausfallarten von Bauteilen, Baugruppen oder Blöcken und ggf. Begründung für Fehlerausschlüsse
5.8	Konzept zur Umsetzung der Erkennung und Beherrschung von zufälligen und systematischen Ausfällen (Selbsttests, Testschaltungen, Überwachungen, Vergleiche, Plausibilitätsprüfungen, Fehlererkennung durch den Prozess usw.)
5.9	Quantitative Aspekte
5.9.1	Zielwerte für $MTTF_d$ und DC_{avg}
5.9.2	Schalthäufigkeit verschleißbehäfteter Bauteile
5.9.3	Häufigkeit von Maßnahmen zur Fehleraufdeckung
5.9.4	Gebrauchsdauer, falls abweichend von der Berechnungsgrundlage der vorgesehenen Architekturen (20 Jahre)
5.10	Betriebs- und Grenzdaten (Betriebs- und Lagertemperaturbereich, Feuchteklasse, IP-Schutzart, Schock-/Vibrations-/EMV-Störfestigkeitswerte, Versorgungsdaten mit Toleranzen usw.) (IP = International Protection, EMV = elektromagnetische Verträglichkeit)
5.11	Anzuwendende Grundnormen für die Konstruktion (zur Ausrüstung, zum Schutz gegen elektrischen Schlag/gefährliche Körperströme, zur Störfestigkeit gegen Umgebungsbedingungen usw.)
5.12	Technische und organisatorische Maßnahmen für einen gesicherten Zugriff auf sicherheitsrelevante Parameter bzw. SRP/CS-Eigenschaften (Manipulationsschutz, Zugangssicherung, Programm-/Datenschutz) und zum Schutz gegen unbefugtes Bedienen (Schlüsselschalter, Code usw.), z. B. bei Sonderbetriebsarten
5.13	Allgemeine technische Voraussetzungen und organisatorische Rahmenbedingungen für die Inbetriebnahme, Prüfung und Abnahme sowie Wartung und Instandhaltung

Source: General specifications, extract BGIA Report 2/2008 on EN ISO 13849-1

Example for an automatic handling system:

Functional description:

The automatic handling system is used to pick up varying height lorry cabs automatically. After pick-up the height of the cab is safely acquired so that the cab cannot be lowered below a certain height in the working area. The automatic system must not exceed a maximum speed in the working area. After the cab has been fully processed, it is set down again at the end of the processing line and the automatic handling system returns via a return path to the start of the line to pick up a cab again....

Boundaries of the machine:

Spatial boundaries: there must be enough space for the workers in the working area so that all the necessary work on the cab can be undertaken.... In the return there must be enough space for the empty automatic system tackle...

Time-related boundaries: description of the service life, description of ageing processes that could cause a change to machine parameters (e.g. brakes). Monitoring mechanisms must be provided for such cases.

Application boundaries: the automatic system automatically collects new cabs and moves them through a processing area. In the processing area there are workers...etc.

The following operating modes are provided: setting up mode, automatic mode and service mode...etc.

Identification of hazards:

The following mechanical hazards are relevant on the automatic handling system:

Hazard 1: Crushing due to falling cab / lifting bar

Hazard 2: Impact due to falling cab / lifting bar

Hazard 3: Crushing due to fast lowering of the cab if there is a fault

Hazard 4:.....

Risk analysis:

G1: The weight of the cab and the lifting bar is so high that irreversible crushing or fatalities may occur.

G2: Due to moving cab / lifting bar, impact with irreversible injuries may occur.

G3:

Risk assessment:

A risk reduction is necessary taking into account all operating conditions.

Inherently (risks from the project) safe design

Moving the cab in x and y direction in the working area is unavoidable. The cab must be moved up/down and forwards in the processing area....











The following measures can be taken:

Avoid hazards due to excessively fast movements

Avoid hazards due to excessively small distances

Example for a hazard analysis:

Gefahrenanalyse

Sicherheitsnachweis für Herstellereklärung		Maschinentyp Verpackungsanlage	Auftrags-Nummer 200-402							
		Kunde	Erstellt: Michael Duesel am 16.10.06 Blatt 1 von 4							
Betriebs- zustand	Gefährdung durch Kurzbeschreibung	Check	Ereignis oder Schenziel	Lösung	Auf- Kl.	St. Kat.	Verwendete Normen und Richtlinien	Hinweise/ Kriterien für Inbetriebnahme und Prüfung	geprüft am	vom
Lineareinheiten										
Automatik und Hand- betrieb	Quetschen Erfassen Einziehen   		Schutz vor Quetschen, Erfassen und Einziehen erforderlich bei: -Linearbewegung in X-Richtung -Linearbewegung in Y-Richtung	Schutzverkleidung 2m hoch, mit Punktschweiß- gitter MW 40 mm Schutztür mit Sicherheits- türschalter			EN 292-2 Abs. 3.2 EN 294 Abs. 4.5.1	Schutzverkleidung vorhanden? Fest mit der Maschine ver- schraubt? ES-Funktion überprüft -Maschine muß sofort anhalten, wenn Türe geöffnet wird		
Strafferzylinder/Schwert										
Automatik und Hand- betrieb	Quetschen Stossen 		Schutz vor Quetschen und Stossen erforderlich bei: -pneumatische Linearbewegung	Schutzverkleidung 2m hoch, mit Punktschweiß- gitter MW 40 mm			EN 292-2 Abs. 3.2 EN 294 Abs. 4.5.1	Schutzverkleidung vorhanden? Fest mit der Maschine ver- schraubt?		
Zentrierung mit Andruckblech										
Automatik und Hand- betrieb	Quetschen Erfassen Einziehen   		Schutz vor Quetschen, Erfassen und Einziehen erforderlich bei: -pneumatischer Schwenkbewegung	Schutzverkleidung 2m hoch, mit Punktschweiß- gitter MW 40 mm Schutztür mit Sicherheits- türschalter			EN 292-2 Abs. 3.2 EN 294 Abs. 4.5.1	Schutzverkleidung vorhanden? Fest mit der Maschine ver- schraubt? ES-Funktion überprüft -Maschine muß sofort anhalten, wenn Türe geöffnet wird		
Schließrollen										
Automatik und Hand- betrieb	Quetschen Erfassen Einziehen   		Schutz vor Quetschen, Erfassen und Einziehen erforderlich bei: -pneumatische Linearbewegung	Schutzverkleidung 2m hoch, mit Punktschweiß- gitter MW 40 mm. Schutzabdeckung aus Blech bzw. Lochblech, Spalte und Lochgröße < 8mm			EN 292-2 Abs. 3.2 EN 294 Abs. 4.5.1	Schutzverkleidung vorhanden? Schutzab- deckung vorhanden? Fest mit der Maschine verschraubt?		

12.3.3 Specification of the functional safety system

Derived from the general hazard and risk analysis for the machine, the active protection functions are to be identified and specified.

Active protection functions are, e.g. safely limited speed in certain system states, monitored stop and standstill functions, range monitoring, processing of monitoring devices such as light grids, safety mats etc.

The safety functions are each to be bounded and the specific requirements defined in relation to function and safety level.

12.3.3.1 Definition of the safety functions

The definition of the safety function must:

State the risk to be covered

Describe the exact function

List all sensors, controls involved

Identify all controllers

Identify the related shutdown circuit.

The definition is intended to form the basis for the specification of the hardware and software design.

For each of the safety functions defined in this manner, any parameters to be used, e.g. max. system speed in the setting up mode etc. are to be defined.

Example for safety functions:

SF1: STO (safe torque off) for protection against safe startup

SF2: Safe speeds

SF3: Safe positions

SF4:.....

12.3.3.2 Performance Level required (PLr) (additional emergency stop)

The Performance Level required must now be determined from the safety functions SF1..... stated above. The decision path can be seen in the example below.



Example for SF1: Result PF = d (source Sistema)

12.3.3.3 Example – specification of the safety functions in tabular form

Seq. no.	Safety function	Ref. from GFA	P Lr	Measured value /sensor	Implementation in software	Required Parameter	Input/ activation	Response/ output
1.1	Limitation of the max. speed of movement, Monitoring of the maximum speed	2.3	e	1 x WCS absolute encoder 1 x incremental encoder on motor / drive wheel	Monitoring using tested safety function SLS for fixed limits:	550mm/s Overspeed distance monitoring: 200mm	Continuous Reset: Reset button	Operation stop SF 1.7.1
1.2	Limitation of the max. speed of movement of the running gear in working area of worker Monitoring of the maximum speed for < 0.33 m/s	2.4	e	1 x WCS absolute encoder 1 x incremental encoder on motor / drive wheel	Monitoring using tested safety function SLS for fixed limits:	60 mm/s Overspeed distance monitoring: 200mm	Identification of working area of worker via position of running gear AND NOT setting up Reset: Reset button	SF 1.7.1
1.3	Limitation of the max. speed of movement of the running gear in the setting up mode Monitoring of the maximum speed for < 0.07 m/s	3.1	d	1 x WCS absolute encoder 1 x incremental encoder on motor / drive wheel	Monitoring using tested safety function SLS for fixed limits:	70mm/s Overspeed distance monitoring: 200mm	Setting up operating mode AND "Bypass safety" button Reset: Reset button	SF 1.7.1
1.4	Running gear collision protection Monitoring of the distances for minimum distance using redundant laser distance measurement	2.5	d	2 x laser distance measuring devices	Monitoring of the distances using tested SAC function. The analogue distance measured values are compared mutually for max. tolerance (analogue sensor diagnostics) Monitored for minimum values (SAC function) Min. distance value 25% of the max. value for measuring device		Running gear outside working area of the worker Reset: Reset button	SF 1.7.1
1.6.1	Running gear sensor system monitoring * for the two running gear sensors	5.1	e	1 x WCS absolute encoder 1 x incremental encoder on motor / drive wheel	Muting of the diagnostics for both running gear sensors using tested SCA function Muting is started before each gap, an incorrect encoder value is then briefly suppressed. In the gap an encoder value outside of 2 to 160000 mm results in muting		Pos 1 (7626 - 7850) Pos 2 (11030-1263) Pos 3 (75134-5338) Pos 4 (145562-145622) Pos 5 (143935-143995) Pos 6 (80000-80060)	SF 1.6.2

12.3.4 Software specification

The software specification relates to the prior specification of the safety functions. It can also be replaced by a correspondingly prepared specification of the safety functions if this contains all specifications (see example in 12.3.3.3).

However, it is recommended to prepare an extracted list. This list should contain the following information:

- Identification of the safety function
- Functional description
- Parameters as far as present
- Triggering event / operating state
- Response / output

The level of detail in the specification should be suitable for subsequent validation of the programming.

Example software specification

Seq. no.	Safety function	PL r	Measured value /sensor	New solution	Input/activation	Response/output
1.4	Monitoring V_rope in relation to V_required Monitoring of the difference between main drive speed and rope drive for maximum value	d	Digital incremental encoder, tacho generator sheave	Monitoring using tested function SLS + SAC with comparison of speed ranges / analogue value range = comparison for diagnostics on the speed acquisition Shutdown 2-channel new (see below)	Continuous Reset: Reset button	Operating stop SF 1.3.1
1.6	Backstop Monitoring for return	d	Mechanical limit switch 22S2 Digital incremental encoder	Monitoring using tested function, direction monitoring SDI	NOT (auxiliary contact 28K4 – inspection movement) Reset: Reset button	Operating stop SF 1.3.1
1.15	Stepwise shutdown 3 Activation of the safety brake	e	-	Processing of SF in SafePLC2	SF 1.2 SF 1.3.2 SF 1.7 SF 1.8	Set safety brake
1.8	Functional standstill	d	Digital incremental encoder	Standstill monitoring using tested function SOS	Controller disable OR Set service brake	SF 1.15/ Set safety brake
1.9	Direction monitoring	e	Digital incremental encoder,	Monitoring using tested function, direction monitoring SDI	28K1 = FORWARD 28K2 = BACK	Operating stop SF 1.3.1

12.3.5 Hardware specification

In the hardware specification, the complete system layout and in particular the components used here are to be described with their specific characteristic data. The hardware specification is used as the basis for determining the safety level achieved based on the architecture and the characteristic data of all devices involved in a safety function.

In addition, the design measures for protection against systematic and common cause failures are to be stated in the hardware specification.

12.3.5.1 Selection of SRP/CS and equipment

The SRP/CS (safety related parts of control system) are to be selected appropriately for achieving the safety level required for each safety function. The components are to be marked with the safety-related function in a complete overview of the system and assigned to the individual safety functions. The safety-related characteristic data are to be determined for these components.

The characteristic data include the following values:

$MTTF_d$ = mean time to dangerous failure

DC_{avg} = average diagnostic coverage

CCF = common cause failure

On a SRP/CS, the software and systematic failures are also to be considered.

In principle, an analysis is to be undertaken on the SRP/CS involved in a safety function according to the scheme sensor / PES / actuator.

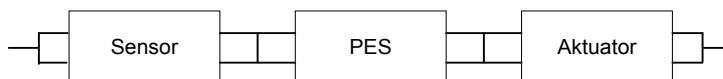

12.3.5.2 Examples for hardware specification

Safety function		Safely limited speed	SF 2.2	Safely monitored limited speed with door open							Comment
Type	Designation	Function	Designation	Characteristic data							
				Architecture	MTTF d [years]	PFH [1/h]	B10d	Source	DC [%]	Source	
Sensor	Sensor 1	Door locking – monitoring of the access door	A 3.1	4			100000	Data sheet	99	Inst. Handb. PSC1	
	Sensor 2.1	Incremental encoder – motor feedback SIN/COS	G 1.1	4	30			Gen. specifications	99	Inst. Handb. PSC1	Cat. 4 in conjunction with eval. PSC1
PES	Safety PLC	Central safety PLC for control system and evaluation of safety-related functions	A 4.1			1.4 E-8		Data sheet PSC1			
Actuator	STO	Safe Torque Off on converter	A 5.1	4	150			Data sheet converter	99	Inst. Handb. PSC1	Cat. 4 in conjunction with 2nd channel
	Mains contactor	Contacteur in the mains cable for the converter	K 5.1	4			20 E6	Data sheet contactor	99	Inst. Handb. PSC1	Cat. 4 in conjunction with 2nd channel

12.3.5.3 Consideration of systematic failures

In addition, systematic failures are also to be considered in the hardware specification.

Example of measures against systematic failures:

Loss of power during operation. If there is a hazard here, a power loss must be considered like an operating state. The SRP/CS must control this state such that the safe state is retained.

Measures against systematic failures according to Annex G DIN EN ISO 13849-1:

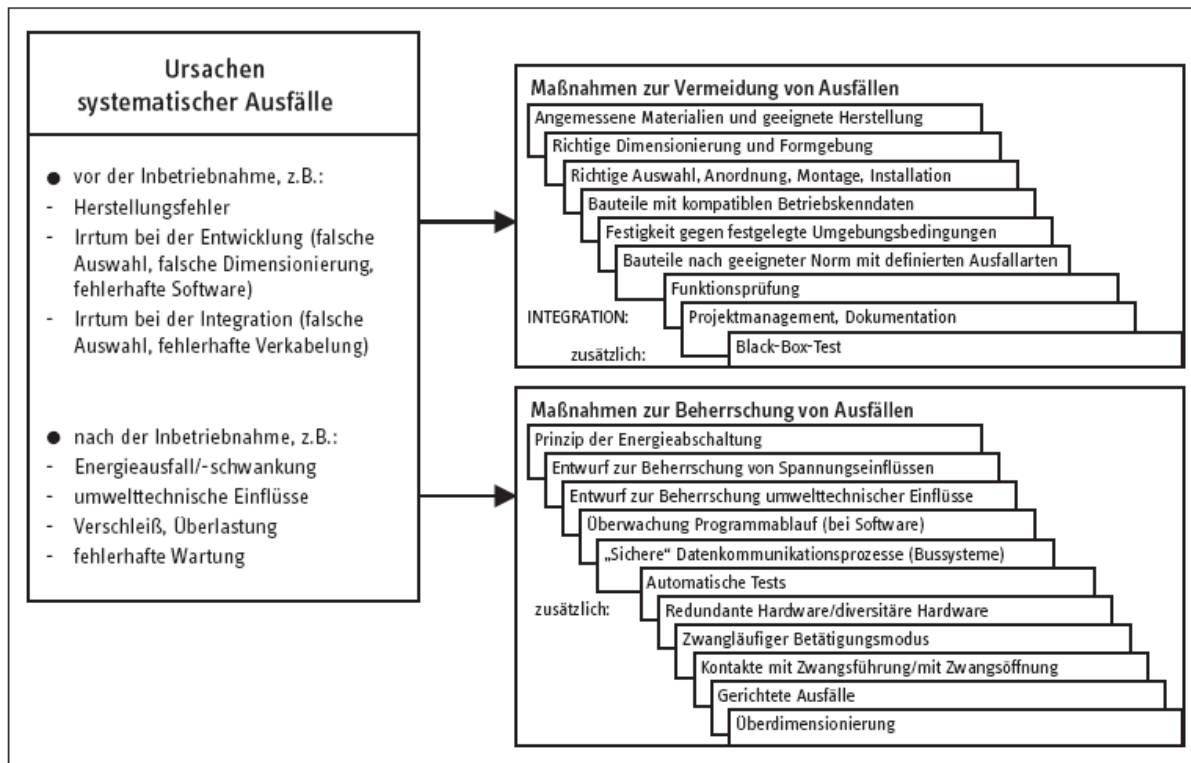

Source BGIA Report 2/2008

Fault exclusions:

If there are fault exclusions for certain devices or system components, these are to be stated and specified in detail.

Fault exclusions can be, e.g. mech. shaft fracture, sticking switching contacts, short-circuits in cables and wires etc.

The admissibility of the fault exclusions is to be justified, e.g. by referencing permissible fault exclusions according to applicable standards e.g. EN ISO 13849-1)

If special measures are necessary for these fault exclusions, these are to be stated.

Examples for fault exclusions and measures assigned:

- Positive locking connection on mech. shaft connections
- Dimensioning based on adequate theoretical principles related to fracture of components in the safety chain
- Positive guidance in conjunction with positive separation on sticking of switching contacts
- Protected laying within the switchgear to avoid short-circuits in cables and wires, as well as laying cables in cable ducts

12.3.6 Hardware and software design

The specifications from the hardware and software specification are implemented in the actual system design.

The specifications for the components to be used and their circuitry from the hardware specification are to be met as are the specifications for the fault exclusions. Both are to be safeguarded using suitable means and are to be documented.

The specifications from the software specification are also to be followed and fully implemented in the software.

In addition, the higher-level specifications for the software from safety-related programming are to be observed. These include:

Modular and clearly structured layout of the program

Assignment of functions to the safety functions

Comprehensible depiction of the functions by means of:

Unambiguous identifiers

Comprehensible comments

Wide-ranging usage of tested functions / function blocks

Defensive programming

12.3.7 Check on the hardware design

On completion of the planning, the hardware design is to be checked for compliance with the specifications from the hardware specification.

In addition, compliance with the specific safety level for each individual safety function is to be checked by means of suitable analysis. The analytical methods are described in the applicable standards (e.g. EN ISO 13849-1).

Circuit diagram analysis:

Compliance with the safety-related aspects of the specifications is to be checked based on the circuit diagram and the parts list.

In particular, to be checked are:

- The component connection circuitry as per specifications,
- The dual-channel layout as far as specified
- The freedom from interaction of parallel, redundant channels.
- The usage of components as per specifications
- The check is to be made by means of a traceable analysis.

12.3.7.1 Iterative check on the safety level achieved

The safety level achieved is to be determined based on the circuit layout (= architecture single-channel / dual-channel / with or without diagnostics), the device characteristic data (information from manufacturer or appropriate sources) and the diagnostic coverage (information from manufacturer of PES or general sources). The appropriate methods are to be found in the underlying safety standard.

As an example, a calculation according to EN ISO 13849-1 is shown:

Safety function:

Safely limited speed with open access door

Schematic layout:

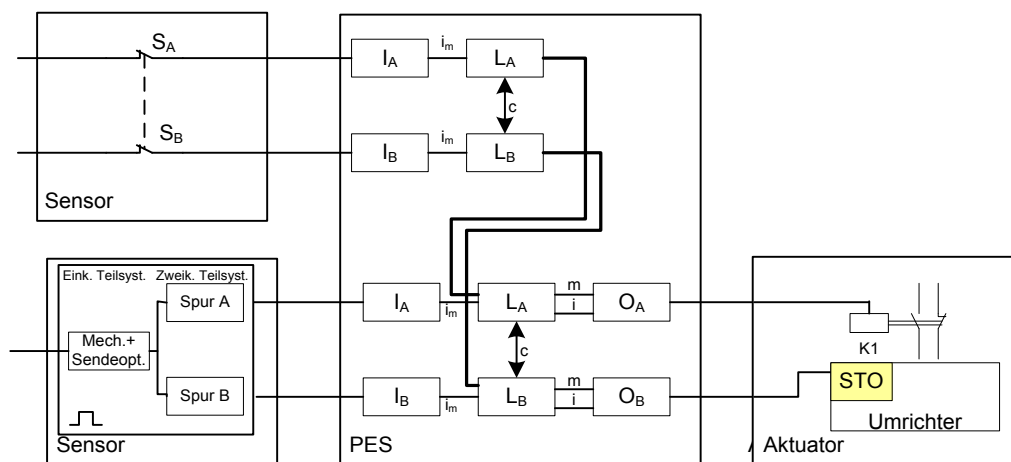

Safety-related schematic layout:

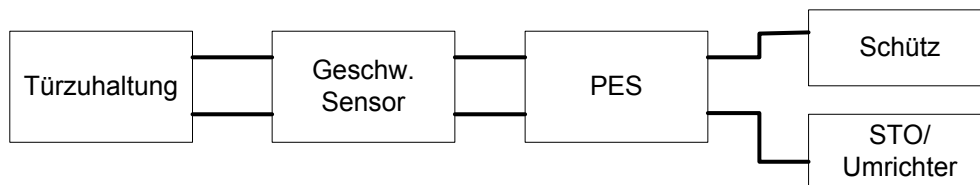

Calculation according to EN ISO 13849-1:

Channel A – shutdown via mains contactor:

Component	MTTFd [years]	DC
Door locking	$B10d = 100000$ $NOP = 30/\text{working days} = 9270/\text{year} (309 \text{ working days/year})$ $MTTFd = \frac{B10d}{0,1 * Nop} = 108 \text{ Jahre}$	$DC_{\text{Switch}} = 99\%$
SIN/COS encoder	$MTTFd_{\text{SinCos}} = 30 \text{ years}$	$DC_{\text{Encoder}} = 99\%$
PES	$PFHd = 1.4 * 10^{-8}$ $MTTFd = \frac{1}{8760 * PFHd} = 8154 \text{ Jahre}$	$DC_{\text{PES}} = 99\%$
Mains contactor	$B10d = 20 * 10^6$ $NOP = 20/\text{working days} = 3990/\text{year} (309 \text{ working days/year})$ $MTTFd = \frac{B10d}{0,1 * Nop} = 32362 \text{ Jahre}$	$DC_{\text{PES}} = 60\%$
$MTTFd_A = \frac{1}{\frac{1}{MTTFd_{\text{Türz.}}} + \frac{1}{MTTFd_{\text{SinCos}}} + \frac{1}{MTTFd_{\text{PES}}} + \frac{1}{MTTFd_{\text{Netzs}}}} = 23 \text{ Jahre}$		

Channel B – shutdown via STO/converter:

Component	MTTFd [years]	DC
Door locking	$B10d = 100000$ $Nop = 30/\text{working days} = 9270/\text{year} (309 \text{ working days/year})$ $MTTFd = \frac{B10d}{0,1 * Nop} = 108 \text{ Jahre}$	$DC_{\text{Switch}} = 99\%$
SIN/COS encoder	$MTTFd_{\text{SinCos}} = 30 \text{ years}$	$DC_{\text{Encoder}} = 99\%$
PES	$PFHd = 1.4 * 10^{-8}$ $MTTFd = \frac{1}{8760 * PFHd} = 8154$	$DC_{\text{PES}} = 99\%$
STO/converter	$MTTFd_{\text{STO}} = 150 \text{ years}$	$DC_{\text{PES}} = 90\%$
$MTTFd_B = \frac{1}{\frac{1}{MTTFd_{\text{Türz.}}} + \frac{1}{MTTFd_{\text{SinCos}}} + \frac{1}{MTTFd_{\text{PES}}} + \frac{1}{MTTFd_{\text{Netzs}}}} = 20 \text{ Jahre}$		

Resulting PL for both channels:

Symmetrisation of both channels:	$MTTFd = \frac{2}{3} \left[MTTFd_A + MTTFd_B - \frac{1}{\frac{1}{MTTFd_A} + \frac{1}{MTTFd_B}} \right] = 21,5 \text{ Jahre}$
DC average value	$DC_{avg} = \frac{\frac{DC_{Switch}}{MTTFd_Türz} + \frac{DC_{SinCos}}{MTTFd_SinCos} + \frac{DC_{PES}}{MTTFd_PES} + \frac{DC_{Schütz}}{MTTFd_Schütz} + \frac{DC_{STO}}{MTTFd_STO}}{\frac{1}{MTTFd_Türz} + \frac{1}{MTTFd_SinCos} + \frac{1}{MTTFd_PES} + \frac{1}{MTTFd_Netzsch}}$ <p>DC_{avg} = 0,9776 ~ 98%</p>
PL	<p>MTTFd = 21.5 years = medium DC_{avg} = 98 % = medium</p> <p>PL =“d“ (from EN ISO 13849-1, Tables 5, 6 and 7)</p> <p>In this case the B10d value for the door monitoring is definitive for the PL. If a higher safety level is to be achieved, a correspondingly higher quality switch is to be used.</p>

Note:

It is also possible to determine the PL using the tool "Sistema" from the BGIA, among others.

12.3.8 Verification of software (program) and parameters

The verification/validation is undertaken in two steps:

- Check on the FUP in relation to the specified functionality
- Check on the FUP against the IL listing in the validation report, and the parameters specified against those in the validation report.

12.3.8.1 FUP check

The FUP actually programmed is to be checked against the requirements in the specification.

Note:

The comparison is all the more efficient the clearer the programming has been structured in relation to the safety functions.

Example:

Safety function:

- Limitation of the max. travel speed of the running gear (FW) to 1.1 VMax
- Monitoring of the maximum speed for < 1.1 VMax
- "FW Max Speed OK", as long as FW Max Speed < 550 mm/s (bridged by "Lock error")
- Monitoring "FW Max Speed" is continuously activated and triggers if a speed of 550 mm/s is exceeded.

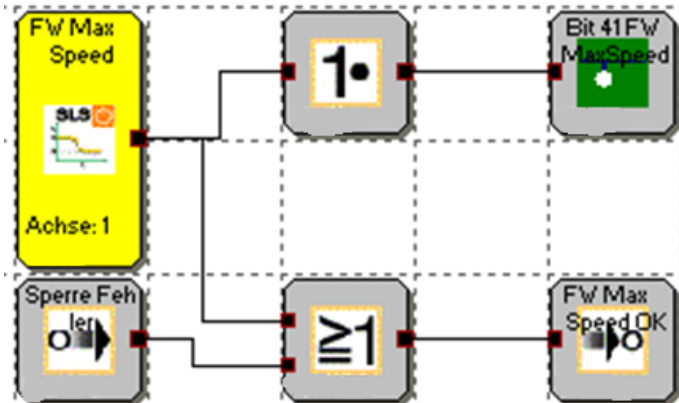

Safety function:

- Limitation of the max. travel speed of the running gear (FW) in the worker's area
- Monitoring of the maximum speed for < 0.060 m/s
- "Safe Speed" monitoring is activated when the running gear is in the "WorkerArea", "Setup" has not been activated and the maximum speed is exceeded.

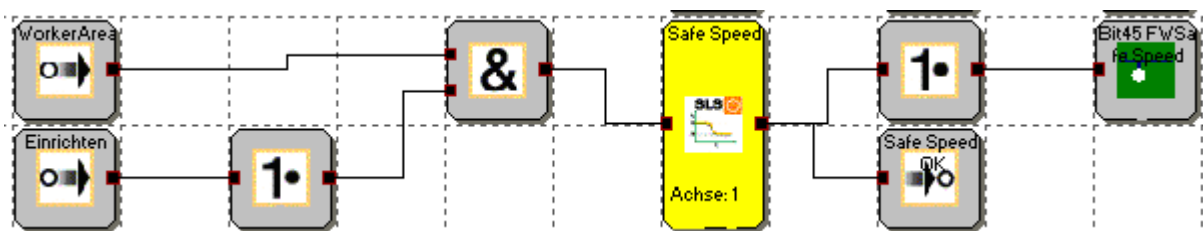

SLS Safe Speed parameters:

60 mm/s, no other parameters

Safety function:

- Engage drive and brake shutdown if emergency stop is actuated or one of the monitoring functions SS1, ECS or SSX is activated and these are not bridged by "gap present".

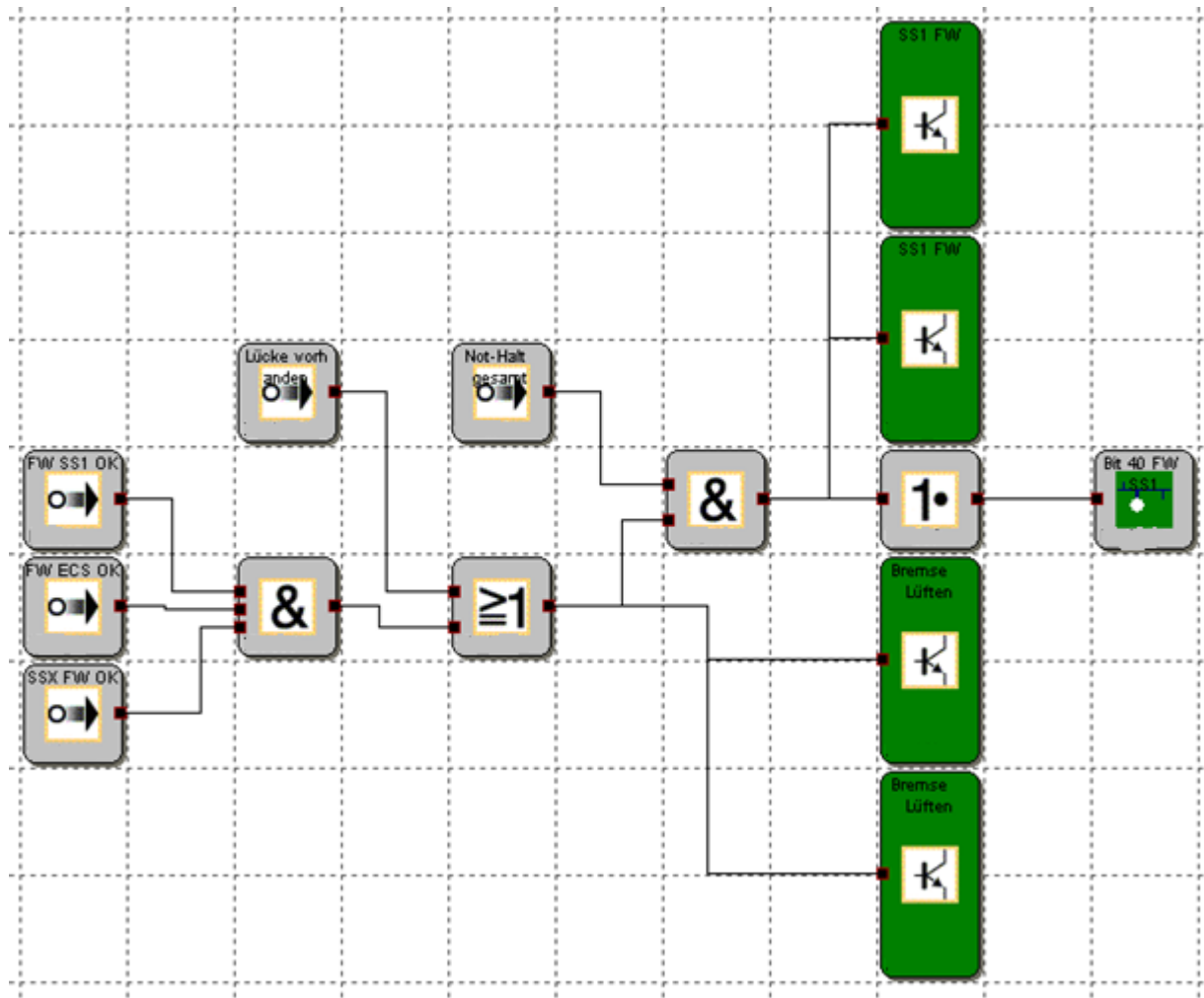

- The running gear is switched off via two "SS1 FW" outputs.
- The brakes are released via two outputs "Release brake".
- A message is sent to the PLC via "Bit 40 FW SS1".
- If there is an emergency stop, the shutdown is implemented immediately.

12.3.8.2 Validating FUP against IL and parameters using validation report

The programming in the FUP is to be compared with the IL listing in the validation report.

Example IL listing in the validation report

Validation report					
PLC program					
Index	Command	Operand			Validated
1	NO1	SLI_EN.1			
2	NO1	SLI_EN.2			
3	NO1	SLI_EN.3			
4	NO1	SCA_EN.1			
5	NO1	SCA_EN.2			
6	NO1	SCA_EN.3			
7	NO1	SLS_EN.2			
8	NO1	SCA_EN.4			
9	NO1	SLS_EN.3			
10	NO1	SLS_EN.4			
11	NO1	SLI_EN.5			
12	SQH				
13	LD	I0.00			
14	ST	MX.2			
15	SQC				
16	SQH				
17	LD	I0.02			
18	AND	I0.03			
19	ST	MX.3			
20	SQC				

A stepwise check is recommended. The check is all the more efficient the more the programming in the FUP has been structured.

After checking the program, the parameters are to be checked against the parameters in the specifications by comparing.

Example SLS:

Validation report				
Safely Limited Speed (SLS)				
Index	Parameter	Value		Validated
SLS - 1	Selected axis:	1		
	Speed threshold:	200	0	
SLS - 2	Selected axis:	1		
	Speed threshold:	500	0	
SLS - 3	Selected axis:	1		
	Speed threshold:	100	0	
	Acceleration threshold:	2	0	
SLS - 4	Selected axis:	1		
	Speed threshold:	50	0	
	SSX ramp assigned:	1		

Example encoder configuration:

Validation report				
Axis configuration / sensor interface				
Axis 1				
General parameters				
Measurement length:	500	0		
Type:	Rotary			
Position processing:	Active			
Maximum speed:	2000	0		
Switch off position:	10	0		
Shutdown speed:	100	0		
Sensors	1		2	
Type:	SSI standard		SSI standard	
Format:	Binary		Binary	
Count direction:	high		high	
Voltage supply:	24V		24V	
Resolution:	1024	Steps/1000 mm	64	Steps/1000 mm
Offset:	0	Steps	0	Steps

General parameters correctly configured			
Parameters sensor 1 correct			
Parameters sensor 2 correct			

12.3.9 Performance of system tests / FIT test (Fault Injection Test)

For the FIT test the manufacturer must prepare a complete list of functions to be tested. This list includes the safety functions defined as well as fault tests for checking the correct response of the SRP/CS to these faults.

Example test list:

No.	Setup	Test	Result
1 Test SLS for max. speed setting up mode			
	Activate setting up mode Movement with max. permitted speed	<ul style="list-style-type: none"> • Diagnostics on the actual speed versus SLS limit • Tamper with the setting up speed so it is above permitted limited speed 	
2 Test SSX for stop category 2			
	Movement with max. speed Actuate EMERGENCY STOP	<ul style="list-style-type: none"> • Diagnostics on the SSX ramp against the actual deceleration ramp • Set an inadmissibly slow deceleration • Move the axis after reaching standstill by tampering with the drive 	
3 Test on the 2-channel door monitoring			
	Select setting up mode operating mode	<ul style="list-style-type: none"> • Diagnostics on the inactive monitoring with door closed (by means of diagnostic function FUP) • Diagnostics on the active monitoring with door open (by means of diagnostic function FUP) • Disconnect a channel and open the door • Generate cross-circuit between the two inputs 	

13 Appendix

13.1 Appendix A – categorisation of the switch types

General note:

The individual switches for the following input elements can be assigned as required to the digital inputs I0 to I13.

Enable switch

Switch type	Remark	PL categorisation according to EN ISO 13849-1	SIL categorisation according to EN 61508
1 normally closed contact	Simple enable switch	PL d	SIL 2
1 normally open contact	Simple enable switch	PL d	SIL 2
2 normally closed contacts	Enable switch for increased requirement	PL e	SIL 3
2 normally closed contacts time monitoring	Monitored enable switch	PL e	SIL 3

Emergency stop

Switch type	Remark	Category categorisation	SIL categorisation
1 normally closed contact	EMERGENCY STOP simple	PL d ⁽¹⁾	SIL 2
2 normally closed contact	EMERGENCY STOP for increased requirement	PL e	SIL 3
2 normally closed contacts time monitoring	EMERGENCY STOP monitored	PL e	SIL 3

⁽¹⁾ Fault exclusions and boundary conditions according to EN ISO 13849-2 are to be observed!

Door monitoring

Switch type	Remark	Category categorisation	SIL categorisation
2 normally closed contact	Door monitoring for increased requirement	PL e	SIL 3
2 normally closed contacts time monitoring	Monitored door monitoring	PL e	SIL 3
1 normally open contact + 1 normally closed contact	Door monitoring for increased requirement	PL e	SIL 3
1 normally open contact + 1 normally closed contact time monitored	Monitored door monitoring	PL e	SIL 3

2 normally open contact + 2 normally closed contact	Door monitoring for increased requirement	PL e	SIL 3
2 normally open contact + 2 normally closed contact time monitored	Monitored door monitoring	PL e	SIL 3
3 normally closed contact	Door monitoring for increased requirement	PL e	SIL 3
3 normally closed contacts time monitored	Monitored door monitoring	PL e	SIL 3

Two-handed operation

Switch type	Remark	Category categorisation	SIL categorisation
2 change-over contacts	Two-hand button for increased requirement	Type III C PL e	SIL3
2 normally open contacts	Monitored two-hand button	Type III A PL c	SIL1

Note:

On these input elements there is a fixed pulse assignment that the user cannot change!

Light curtain

Switch type	Remark	Category categorisation	SIL categorisation
2 normally closed contact	Light curtain for increased requirement	PL e	SIL 3
2 normally closed contacts time monitoring	Monitored light curtain	PL e	SIL 3
1 normally open contact + 1 normally closed contact	Light curtain for increased requirement	PL e	SIL 3
1 normally open contact + 1 normally closed contact time monitored	Monitored light curtain	PL e	SIL 3

Operating mode selector switch

Switch type	Remark	Category categorisation	SIL categorisation
2 positions	Monitored operating mode selector switch	PL e	SIL 3
3 positions	Monitored operating mode selector switch	PL e	SIL 3



Safety instructions:

- On a state change on the switch, it is to be ensured by the SafePLC2 program to be written that the outputs on the module are deactivated

Sensor

Switch type	Remark	Category categorisation	SIL categorisation
1 normally closed contact	Simple sensor input	PL d	SIL 2
1 normally open contact	Simple sensor input	PL d	SIL 2
2 normally closed contact	Sensor input for increased requirement	PL e	SIL 3
2 normally closed contacts time monitoring	Monitored sensor input	PL e	SIL 3

1 normally open contact + 1 normally closed contact	Sensor input for increased requirement	PL e	SIL 3
1 normally open contact + 1 normally closed contact time monitored	Monitored sensor input	PL e	SIL 3

Start / Reset

Switch type	Remark	Category categorisation	SIL categorisation
1 normally open contact	Simple alarm reset (edge evaluation)	--	--
1 normally open contact	Simple logic reset	PL d	SIL 2
1 normally open contact	Simple start monitoring (special function)	--	--

Note:

The alarm reset input can be operated with a continuous voltage of 24 V and is edge controlled.

13.2 CE – declaration of conformity



EC declaration of conformity for safety components in the context of the EC directive

EU-Konformitätserklärung



Original
 K.A. Schmersal GmbH & Co. KG
 Möddinghofe 30
 42279 Wuppertal
 Germany
 Internet: www.schmersal.com

Hiermit erklären wir, dass die nachfolgend aufgeführten Bauteile aufgrund der Konzipierung und Bauart den Anforderungen der unten angeführten Europäischen Richtlinien entsprechen.

Bezeichnung des Bauteils: PROTECT-PSC1-C-10
 PROTECT-PSC1-C-100

Typ: PROTECT-PSC1-C-10,
 -PSC1-C-10-FB1, -PSC1-C-10-FB2, -PSC1-C-10-MC,
 -PSC1-C-10-SDM1, -PSC1-C-10-SDM1-FB1, -PSC1-C-10-SDM1-FB2,
 -PSC1-C-10-SDM1-MC,
 -PSC1-C-10-SDM2, -PSC1-C-10-SDM2-FB1, -PSC1-C-10-SDM2-FB2,
 -PSC1-C-10-SDM2-MC,
 -PSC1-E-31-12DI-10DIO, -PSC1-E-33-12DI-6DIO-4RO,
 PROTECT-PSC1-C-100,
 -PSC1-C-100-FB1, -PSC1-C-100-FB2, -PSC1-C-100-MC,
 -PSC1-E-21-SDM1, -PSC1-E-22-SDM1-2, -PSC1-E-23-SDM2,
 -PSC1-E-24-SDM2-2,
 -PSC1-E-131-12DI-10DIO, -PSC1-E-133-12DI-6DIO-4RO,
 PROTECT-PSC1-E-37-14DI-4DO-2RO-RIO

Beschreibung des Bauteils: Sichere Kompaktsteuerung, mit oder ohne Achsüberwachung;
 I/O-Erweiterungsmodule, mit oder ohne Relaisweiterung

Einschlägige Richtlinien: Maschinenrichtlinie 2006/42/EG
 EMV-Richtlinie 2014/30/EU
 RoHS-Richtlinie 2011/65/EU

Angewandte Normen: EN 61800-5-2:2007,
 EN ISO 13849-1:2015,
 EN 61508 Teile 1-7:2010,
 EN 62061:2005 + AC:2010 + A1:2013 + A2:2015

Benannte Stelle der Baumusterprüfung: TÜV Rheinland Industrie Service GmbH
 Alboinstr. 56, 12103 Berlin
 Kenn-Nr.: 0035

EU-Baumusterprüfbescheinigung: 01/205/5526.00/16

Bevollmächtigter für die Zusammenstellung der technischen Unterlagen: Oliver Wacker
 Möddinghofe 30
 42279 Wuppertal

Ort und Datum der Ausstellung: Wuppertal, 16. November 2016

Rechtsverbindliche Unterschrift
 Philip Schmersal
 Geschäftsführer

PSC1-C-100-B-DE